

INSTALLATION INSTRUCTIONS

CLOPAY CONSUMER SERVICES • 1-800-225-6729



INSTRUCTIONS COMPATIBLE WITH THE FOLLOWING MODELS: **AX,AXU**

STEP 1 - BEFORE YOU BEGIN

- Verify you have all parts and materials required for installation.
 - Door Components (See Page 5).

If missing parts or damaged sections, call Clopay Consumer Services 1-800-225-6729.
- Read instructions completely and/or watch installation video.
- HEADROOM:** Verify appropriate amount of headroom to install door (STEP 3).
- LOW HEADROOM:** Special instructions and additional hardware may be required (STEP 3, Table 3-B).
- INSTALLATION TIME:** Allow enough time to complete installation. Garage will be open and unsecured during installation and will not be able to be used until tracks are installed.
 - Removing existing door will take approximately 1–3 hours.
 - Typical installation time is 9–12 hours.
- TRACK AND HARDWARE:** Express warranties apply only to doors installed using original, factory-supplied sections, parts and hardware and in strict adherence with these instructions.

WARNING

Never reuse old track or hardware when installing a new door as it may cause installation problems or door to fall which could result in serious personal injury or property damage.

- AUTOMATIC DOOR OPENER:** Installation of a reinforced mounting point is required to avoid damage (STEP 11 or STEP 16). Sold separately.
- DRILLING:** Take care not to drill through outside steel skin unless otherwise instructed.
- HIGH WIND AREAS:** Doors installed in high windload regions (Florida and other high wind-prone areas) may require additional reinforcement. Refer to Supplemental Instructions for details if applicable.

TABLE OF CONTENTS

STEP 2	Read Safety Information	2
STEP 3	Check Headroom, Backroom, Sideroom	3
STEP 4	Review Complete Door Assembly and Verify Hardware	4–6
STEP 5	Remove the Existing Door	7
STEP 6	Prepare the Opening	8
STEP 7	Prepare the First (Bottom) Section	9–10
STEP 8	Install Lift Handles	11–13
STEP 9	Install Door Sections	14–16
STEP 10	Reinforce the Top Section for Garage Door Opener	17
STEP 11	Assemble and Install the Track	18–20
STEP 12	Install Lock (If Included)	21
STEP 13	Install Pull Rope (Manually Opened Doors Only)	21
STEP 14	Install Standard Torsion Springs	22–25
STEP 15	Install Solid Shaft Torsion Springs	25–27
STEP 16	Install Low Headroom Front Torsion Springs	27
STEP 17	Attach Automatic Garage Door Opener	28
CARE & MAINTENANCE		29–31
WARRANTY		32

INSTALLATION VIDEO:

<http://www.clopaydoor.com/residential/buyingguide/residential-installation-videos>

or scan the QR code on the right.

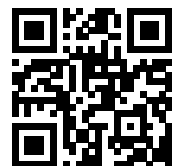

STEP 2 – READ THIS SAFETY INFORMATION - IMPORTANT!



WARNING

TO PROTECT YOURSELF FROM INJURY, YOU MUST CAREFULLY READ THE FOLLOWING SAFETY INFORMATION AND WARNINGS BEFORE YOU INSTALL OR USE YOUR NEW GARAGE DOOR!

BEFORE INSTALLING YOUR DOOR

- You can install your new garage door yourself if:
 - a) you have help (it may weigh up to 150 lbs.)
 - b) you have the right tools and reasonable mechanical aptitude or experience
 - c) you follow these instructions very carefully
- Garage doors use springs to balance them. There are two types of springs – extension or torsion. Each of these is available in either a standard or EZ-SET® assembly option. Please look at the drawings on Page 4 to see which springs your old door has. If your door has a different type of spring, consult the original manufacturer's instructions for removal.
- If your old door uses torsion springs, do not attempt to remove the door or the springs yourself. Have a qualified door repair service remove them. Attempting to remove a torsion spring assembly without proper training or tools may result in an uncontrolled release of spring force which can cause serious or fatal injury (Page 4).
- If removing a garage door that has extension springs, follow the instructions carefully (Page 7), including the use of C-clamps or locking pliers on both sides of the door in order to keep the door from moving once the springs are removed.
- Springs, cables and bottom fixtures are under strong spring tension. Do not attempt to loosen any fasteners on these components. You could suddenly release spring forces and risk severe injury.
- Doors equipped with automatic garage door openers can cause serious injury or death if not properly adjusted and operated. To ensure safety of these doors:
 - a) test the sensitivity of the garage door opener's safety reverse mechanism monthly
 - b) if your door has a pull-down rope, you must remove it
 - c) make sure the door remains unlocked
 - d) ensure door is properly reinforced
 - e) do not allow children to play with the controls
- DO NOT attempt to install the door during windy weather conditions. The door sections may be blown down causing serious injury or property damage.
- Manufacturer disclaims all liability for any installation that is not in compliance with these installation instructions or applicable state or county building codes.

WHILE INSTALLING YOUR DOOR

- Use only the track specified and supplied with the door.
- Bolts must be installed at the rear end of horizontal tracks. These act to stop the rollers and keep the door from rolling off the back of the track.
- Track installations must use sway braces on the rear track hangers to prevent sideways movement. If the tracks are not firmly stabilized they might spread, allowing the door to fall and cause severe injury and damage.
- Do not attach any brackets directly to drywall or sheet rock. All track brackets, flag brackets and spring brackets should only be attached directly to 2" × 6" wood jambs. Otherwise, brackets could pull out of the drywall with dangerous force.

AFTER INSTALLING YOUR DOOR

- The brackets at the bottom corners of your garage door are under great tension. Do not attempt to loosen any bracket fasteners except when and as directed in detail in the following instructions. Otherwise, the bracket could spring out with dangerous force.
- Do not permit children to play beneath or with any garage door or electronic operating controls.
- Keep hands and fingers clear of section joints, track and other door parts when the door is opening and closing to avoid injury. In particular, do not place fingers in section joints in order to close the door, as finger pinch, crush or amputation will result. The lift handles are located for safe operation as well as easy use.
- If the garage door and/or any of the supporting track are damaged, operating the door could be hazardous. Contact Clopay Consumer Services.
- If repairs are ever required to your door, safety and trouble-free operation can be best assured by using original replacement parts.
- Once you have completed the installation of your new garage door, please be sure that your garage complies with all applicable ventilation requirements before you enclose any vehicles in the garage. Good ventilation avoids fire and health hazards caused by fumes accumulating within a well-sealed garage.
- Only approved residential garage door openers are permitted to be used in residential applications. A residential application is a building for four families or less, or a garage that is serving the primary residence.
- Install operator control panel away from garage door track and the door itself. Keep body parts away from track at all times when operating an opener or opening/closing a garage door.



In the interest of safety this symbol means WARNING or CAUTION. Personal injury and/or property damage may occur unless instructions are followed carefully.

STEP 3 - CHECK HEADROOM, BACKROOM, SIDEROOM

Headroom Requirement:

- Headroom is space needed above top of door for door, overhead tracks and springs. Measure to check that there are no obstructions within that space (Fig. 3-A).
- Refer to Table 3-A for standard headroom requirements.
- Track radius can be determined by measuring dimension "R" (Fig. 3-B).
 - If "R" equals 11" to 12", it is a 12" radius track.
 - If "R" equals 14" to 15", it is a 15" radius track.
- Determine which type of spring you have (STEP 4).

NOTE: If there is restricted headroom, several low headroom remedies are available (Table 3-B). Installation of these options differ from installation of a standard headroom door. Supplemental instructions are included with hardware of each low headroom option.

Rough Opening:

- Rough opening (minus stop mold) = same size as door (Fig. 3-A).

Backroom Requirement:

- Measured from back of door into garage, and should be at least 18" more than height of garage door (Fig. 3-A).

Sideroom Requirement:

- Minimum 3-3/4" is needed on each side of door on interior wall surface to allow for attachment of vertical track assembly.
- Minimum 4-1/2" is needed on each side of door above opening for torsion spring attachment.

NOTE: If you are installing an automatic opener, about 3" of additional headroom at the center plus additional backroom is needed. Check door opener instructions.

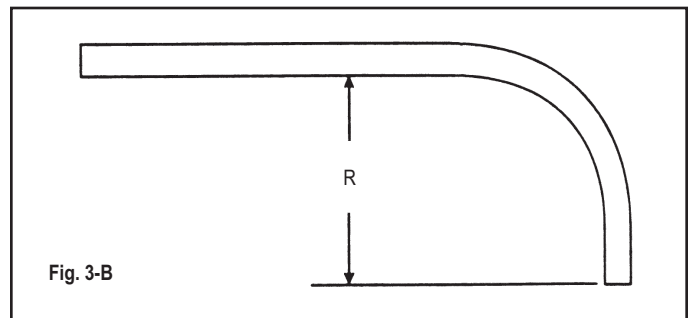
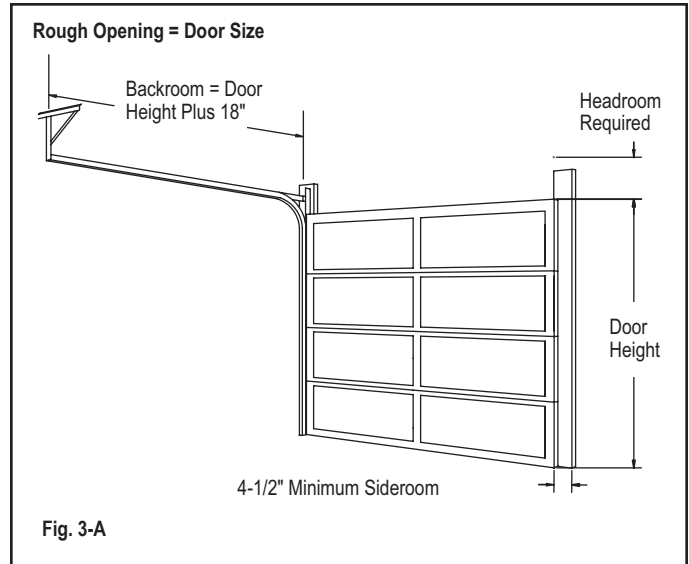

Table 3-A: Standard Headroom Requirement Chart

Spring Type	Track Radius	Headroom Required
Torsion Spring	12"	12"
Torsion Spring	15"	14"

Table 3-B: Low Headroom Options

Spring Type	Low Headroom Option	Reduces Required Headroom to:	How can I get this option?
Torsion	Low Headroom Track (Front Mount Spring)	9-1/2"	Available from and should be installed by professional installer only
Torsion	Low Headroom Track (Rear Mount Spring)	4-1/2"	Available from and should be installed by professional installer only

STEP 4 - REVIEW COMPLETE DOOR ASSEMBLY AND VERIFY ALL HARDWARE IS PRESENT

FINAL GARAGE DOOR ASSEMBLY EXTENSION SPRING SYSTEM SHOWN

Typical Garage Door Installation Illustration

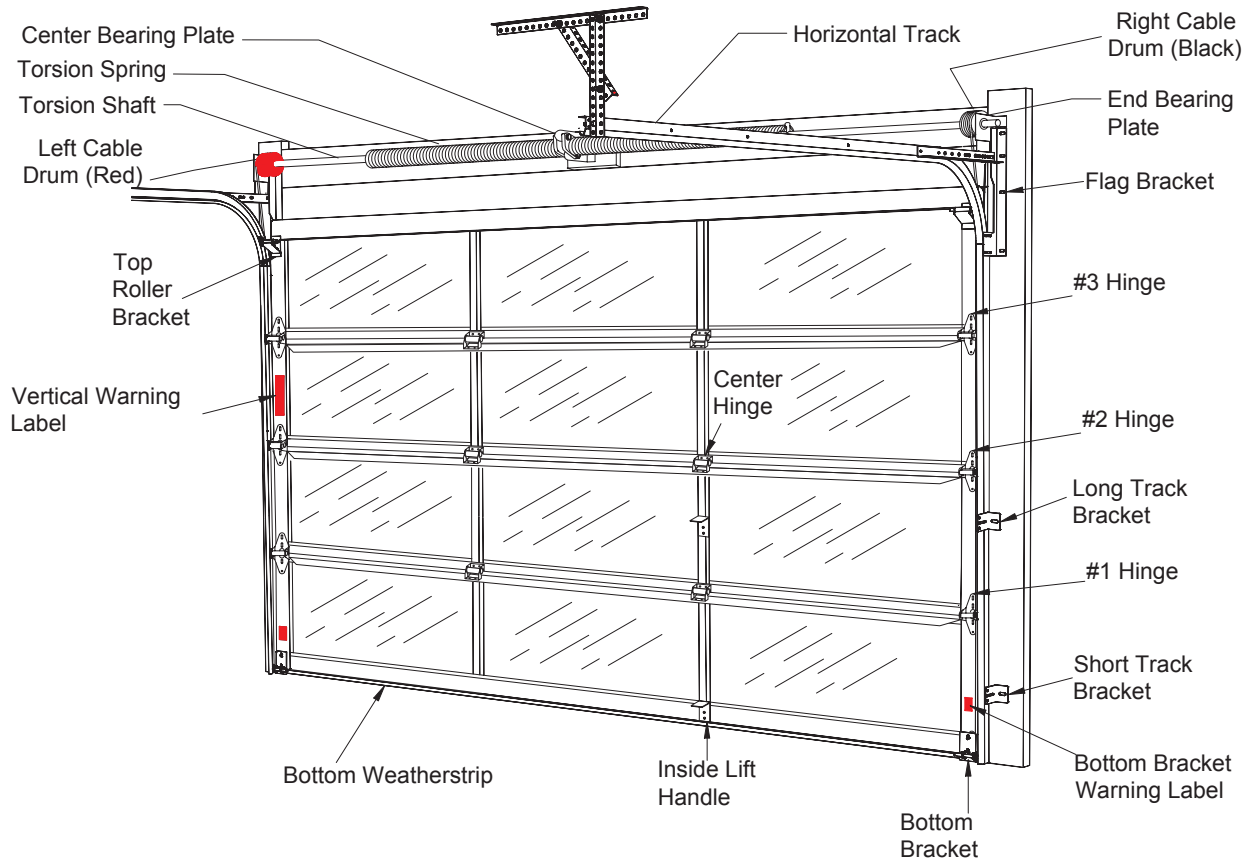

SPRING SYSTEMS

STANDARD TORSION SPRING SYSTEM

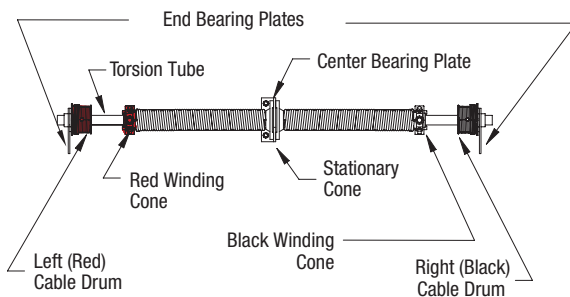

EZ-SET® TORSION SPRING SYSTEM

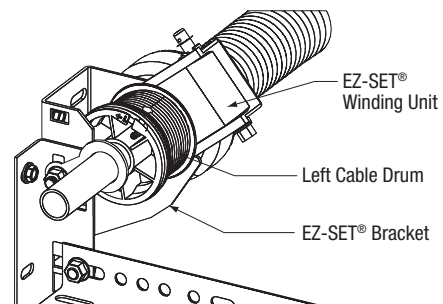













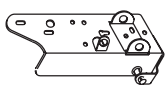
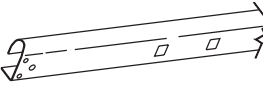

NOTE: The above illustrations represent a composite of many features found on a variety of garage doors. While not representative of any one door, it provides a handy reference for the location of specific components. Doors with torsion springs may require EITHER one or two springs depending on the door weight. Consult your spring manual.

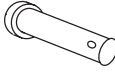
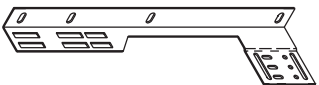

HARDWARE COMPONENTS INCLUDED





NOTE: All doors will receive (1) spring kit and (1) or more springs. Separate spring installation supplemental instructions should be included with door hardware. This supplement contains a list of all spring related hardware along with instructions on proper spring installation.

All doors will receive (2) of these items:

	Track Bracket (Longer)		3/8"-18 x 3/4" Lg. Carriage Bolt		3/8" Washer
	Track Bracket (Shorter)		Top Bracket		Curved Horizontal Track
	#2 Hinge		Bottom Bracket (1 Pair)		Vertical Track
	#3 Hinge		Horizontal Angle		Cable Assembly
	Cable pin		Flag Bracket (1 Pair)		3/8" Hex Nut
			Long Stem Rollers		Cotter pin

(While not representative of any one model, the quantities below can be used as a guide. In some instances, extra screws/bolts are provided in the event of strip out or loss of parts. Quantities for doors over 8'0" high may be different, see extended height supplement.)

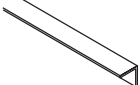
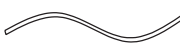

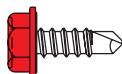







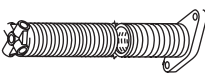
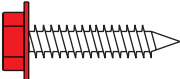

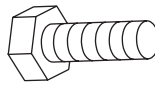
	3/4" combo hinges for doors w/fin.	Single Car Doors 8' - 10'W x 6'6" - 8'0"H	TBD		#1 hinge for doors w/o fin.	Single Car Doors 8' - 10'W x 6'6" - 8'0"H
		Double Car Doors 16'W x 6'6" - 8'0"H	TBD			Double Car Doors 16'W x 6'6" - 8'0"H

Description:	Qty.	Description:	Door Size:	Qty.
	1/4" Flange Nut	Double Car Doors 16'W x 6'6" - 8'0"H	4 Section Doors	8
			5 Section Doors	10
	#14 x 5/8" Hex Head Sheet Metal Screw	Single Car Doors 8' - 10'W x 6'6" - 8'0"H	Single Car Doors 8' - 10'W x 6'6" - 8'0"H	2
		Double Car Doors 16'W x 6'6" - 8'0"H	Double Car Doors 16'W x 6'6" - 8'0"H	2
	1/4" x 5/8" Hex Hed. Bolt	Single Car Doors 8' - 10'W x 6'6" - 8'0"H	Lift Handle/ Step Plate	2
		Double Car Doors 16'W x 6'6" - 8'0"H	All Doors	2
	Struts*	Single Car Doors 8' - 10'W x 6'6" - 8'0"H	1/4" x 5/8" Track Bolt	16
		Double Car Doors 16'W x 6'6" - 8'0"H	Single Car Doors 8' - 10'W x 6'6" - 7'0"H	22
			Double Car Doors 16'W x 6'6" - 7'0"H	22
	Pull Rope	All Doors	5/16" x 1-5/8" Lag Bolt	10
			4 Section Doors	12
			5 Section Doors	12
	Handle Spacer	All Doors	Lift Handle	2
			All Doors	2
	Set Screw	All Doors	#2 Slide Lock	1
			All Doors	1
	1/4" x 3/4" Hex Hd. Self-tapping Screw (Red Head)	All Doors	See next page for Additional Materials Needed (Not Included).	
			10	

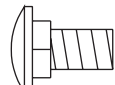
*More struts may be required in high windload areas.

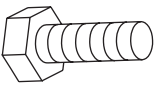
TORSION SPRING HARDWARE COMPONENTS INCLUDED

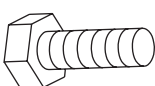
NOTE: While not representative of any one model, the quantities below can be used as a guide. In some instances, extra screws/bolts are provided in the event of strip out or loss of parts. Quantities for doors over 8'0" high may be different, see extended height supplement.

Description:		Qty.	Description:	Door Size:	Qty.
 Torsion Spring	Single Car Doors 8' - 10'W x 8'0"H	1	 5/16" x 1-5/8" Lag Screw (Red Head)	Single Car Doors 8' - 10'W x 8'0"H	2
	Double Car Doors 16'W x 8'0"H	1 or 2		Double Car Doors 16'W x 8'0"H	2 or 4
 End Bearing Plate	All Doors	2	 3/8" x 3/4" Hex Head Bolt	All Doors	4
 Torsion Tube*	All Doors	1	 3/8" Flange Nut	All Doors	10
 Center Bearing Plate	Single Car Doors 8' - 10'W x 8'0"H	1	 3/8"-16 x 3/4" Carriage Bolt	All Doors	4
	Double Car Doors 16'W x 8'0"H	1 or 2			
 Cable Drums	All Doors	2	 3/8" x 1" Hex Head Bolt	Doors With One Spring	2
 Steel Center Bearing	All Doors	1	 3/8" x 1-5/8" Hex Head Bolt	Doors With Two Springs	0
				Doors With One Spring	0
 5/16" x 1-5/8" Lag Screw	All Doors	2 per center bearing plates		Doors With Two Springs	2

* Some heavier doors receive a solid shaft and not a torsion tube

ADDITIONAL MATERIALS NEEDED (NOT INCLUDED)

* More aluminum angle may be required in high windload areas. (While not representative of any one model, the quantities below can be used as a guide. In some instances, extra screws/bolts are provided in the event of strip-out or loss of parts.)

MATERIALS NEEDED (NOT INCLUDED)

General

- (1) Can of Clopay® Pro-Lube
- (24) 10d 3" common nails
- Stop molding
- Wood shims
- Wood block
- Rope

Rear Track Hanger Specific

- (1) Rear Track Hanger Kit or material to make track hanger
- 1-1/4" x 1-1/4" minimum 13 ga. (3/32") minimum thickness punched angle
- (10) 3/8" x 1" bolts and nuts
- (6) 5/16" x 1-1/2" lag screws

TOOLS NEEDED (NOT INCLUDED)

- Work gloves
- Safety goggles
- C-clamps or locking pliers
- Hammer
- Flathead screwdriver
- Measuring tape
- Level
- Socket wrench set
- 7/16" and 9/16" box wrenches
- Drill, 1/4", 3/16" and 3/8" drill bits, 7/16" and 9/16" drive bits
- Stepladder
- Sawhorses (with non-abrasive carpet or other soft material on top surface) or other supports for placing section on while assembling
- Hacksaw
- Wood saw
- Angle square
- Additional tools may be required for spring installation

STEP 5 - REMOVE THE EXISTING DOOR

Step 5-1: Remove Existing Door Springs

NOTE: Garage doors use springs to balance door weight. Springs are one of two types – extension or torsion. Each of these is available in either a standard or EZ-SET® assembly option.

- Use illustrations in STEP 4 to determine which springs existing door has. If existing door's spring type is not found, please consult spring manufacturer.

⚠ WARNING

Serious injury could result from an uncontrolled release of spring forces if spring tension has not been released before other work begins.

⚠ WARNING

To avoid pinch and other crushing injuries, keep hands and fingers clear of section joints, track and other door parts while door is opening and closing.

NOTE: Some large doors can weigh as much as 500 lbs. and single car doors as much as 200 lbs. when spring tension is removed.

Standard Torsion Springs:

⚠ WARNING

If present door uses standard torsion springs, DO NOT attempt to remove door or springs yourself. They should be removed by a qualified door service professional. Attempting to remove a torsion spring assembly without proper training and tools may result in an uncontrolled release of spring forces which can cause serious injury.

Standard Extension Springs:

⚠ WARNING

Extension adjustments or removal should only be made with door in up position. To avoid damage or serious injury from door falling, use two or more helpers to assist in lowering door.

- Raise door to full open position.
- Place C-clamps or locking pliers tightly on both sides of track under door so door is held securely in place (Fig. 5-A).
- With door fully open, most spring tension has been removed.
- Keeping C-clamps in place to keep door from falling, detach cable at both ends.
- Disassemble and remove springs and cable completely from door.

NOTE: Wood blocks should be placed underneath door when closing to prevent fingers from being trapped.

- Remove C-clamps from track and carefully close door.
- Weight of door will not be apparent when you first begin to close door. Door will feel progressively heavier as it is lowered until its full weight is realized about one foot from floor.

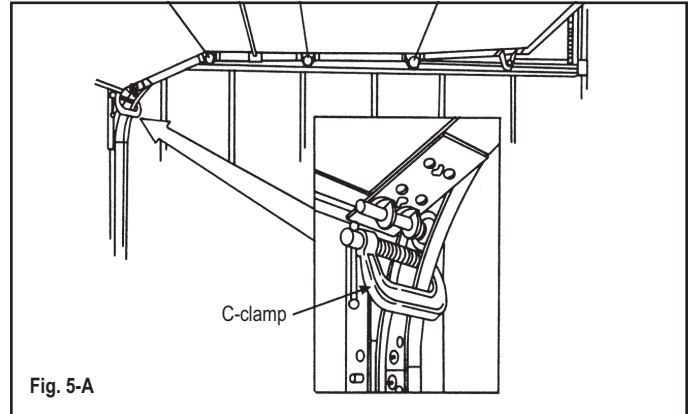

Fig. 5-A

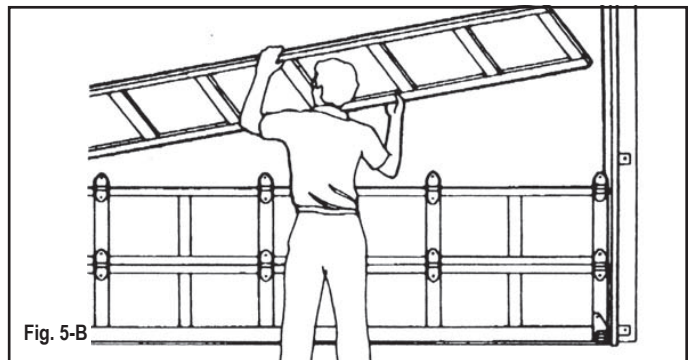

Fig. 5-B

EZ-SET® Extension Springs or EZ-SET® Torsion Springs:

⚠ WARNING

To avoid damage or serious injury, use two or more helpers to assist in lowering door. EZ-SET® torsion springs adjustments or removal should only be made with door in down position.

- With door in down position, position drill with 7/16" socket bit over winding unit.
- Using reverse (counter-clockwise) direction on drill, remove all tension from spring. Repeat for each side.
- After spring tension has been removed, detach lift cables at both ends.
- Disassemble and remove springs and cable completely from door.

Step 5-2: Remove Door Sections and Track

- After removal of door springs, door can now be disassembled.
- Starting with top section, remove hardware and unstack sections one at a time (Fig. 5-B).
- After all sections have been removed from opening, detach all remaining track and hardware from jambs.
- Hangers that attach rear ends of overhead track to ceiling (rear track hangers) in many cases can be reused on new door. Be sure they are made of 13 ga. (3/32") or heavier steel and are not loose or unstable.

⚠ WARNING

To avoid installation and operation problems from using worn, damaged or incompatible track, use only track specified and supplied with door. DO NOT attempt to reuse old track.

STEP 6 - PREPARE THE OPENING

NOTE: Rough opening (framed opening without stop molding) = door size.

Step 6-1: Framing

- If old door was removed, inspect jambs for rotted or damaged wood and replace immediately.
- Inside of door opening should be framed with 2" × 6" lumber.
- Vertical jamb should extend past opening (Fig. 6-A) to match headroom required (Table 3-B).
- Jambs should be plumb and header should be level.
- Be sure bolts fastening jambs to wall are flush.

IMPORTANT: The wood anchor pad is used to mount the torsion spring and has specific requirements for wood quality, species and attachment that must be met.

Step 6-2: Stop Molding

- Door stop molding should be temporarily but securely nailed to edges of jambs and flush with inside framing (Fig. 6-B).

NOTE: Stop molding with built-in weatherseal is offered.

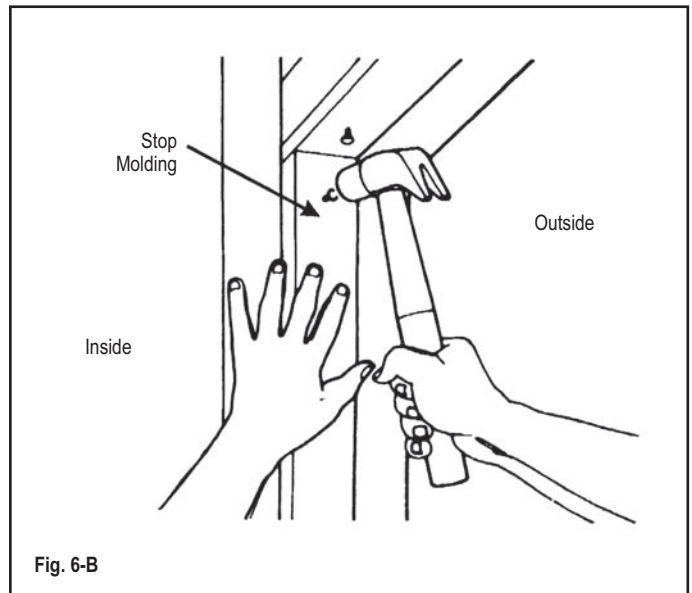
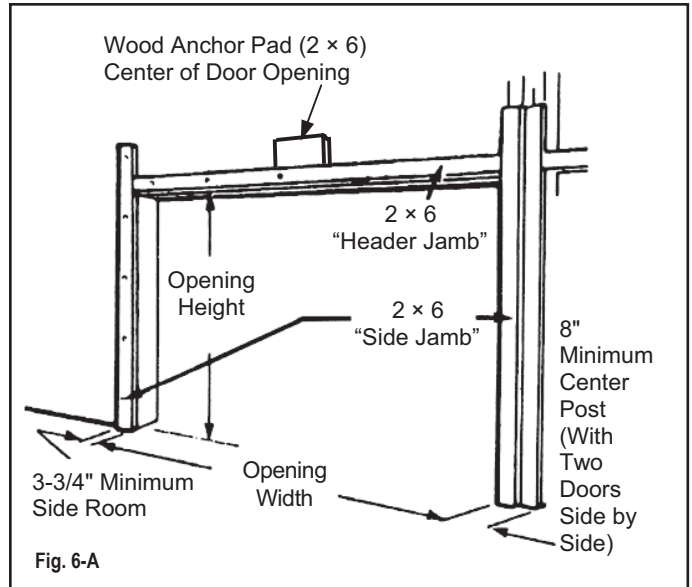

STEP 7 - PREPARE FIRST (BOTTOM) SECTION

Step 7-1: Locate Bottom Section

- Find section with aluminum weatherstrip retainer fastened to one edge. Retainer is on bottom edge of bottom section (Fig. 7-A).
- Cover sawhorses with carpet or cloth as not to scratch section.
- Place section on sawhorses face down. Use two sets for doors over 10' wide.

Step 7-2: Attach Lift Cable to Brackets

- Attach lift cable to bottom bracket by inserting bottom bracket pin through the inside of bottom bracket, the looped end of the lift cable and the outside ear of the bottom bracket. Secure with cotter pin (Fig. 7-B for standard door, Fig. 7-C for low headroom door).

Step 7-3: Attach Bottom Brackets

- Using (5) #14 × 3/4" red-colored self-drilling screws, attach bottom brackets to bottom corners of door section (Fig. 7-D).

⚠ WARNING

Failure to use red-colored fasteners for attachment of bottom brackets may cause sections to fall or spring to break free when spring tension is applied, which can result in severe injury.

Step 7-4: Attach Hinges

- Hinges are stamped with numbers 1, 2 and 3 on the side of the hinge that attaches to the section. (Number 4 is stamped on 5-section door only.)
- Attach a #1 hinge at each end at top edge using (2) #14 × 5/8" hex head sheet metal screws (Fig. 7-E).

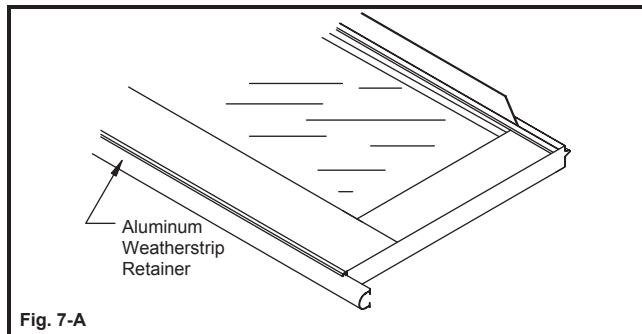

Fig. 7-A

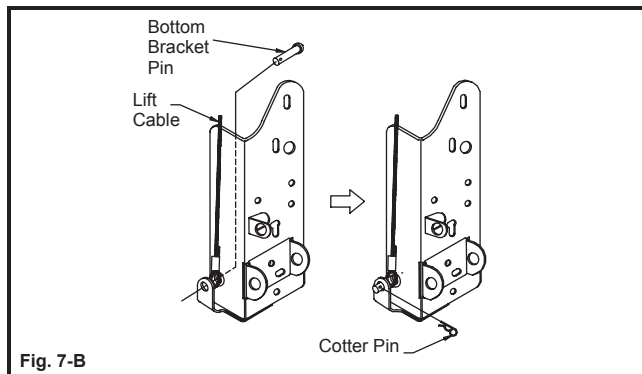

Fig. 7-B

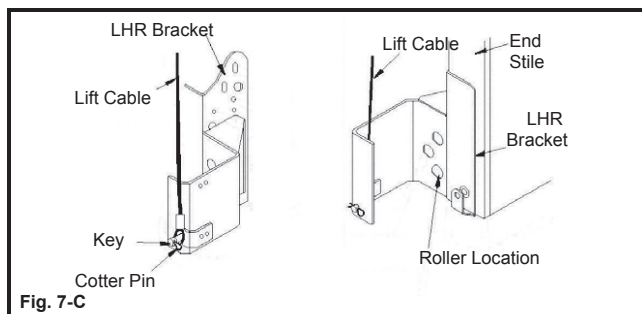

Fig. 7-C

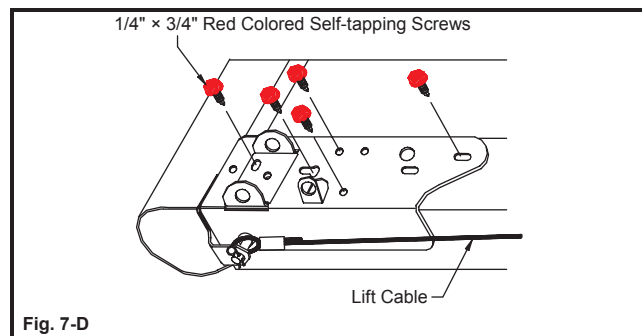

Fig. 7-D

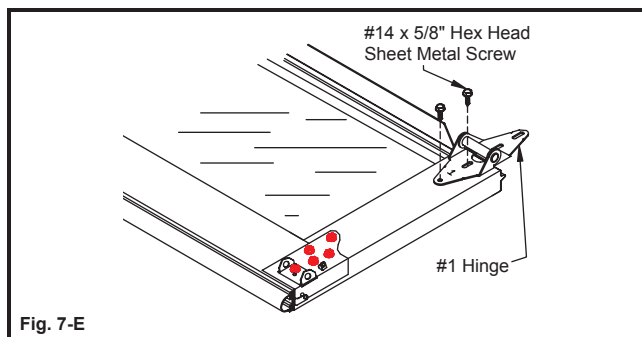

Fig. 7-E

STEP 7 - PREPARING BOTTOM SECTION AND REINFORCEMENT REQUIREMENTS

Step 7-5: Attach Center Hinges and Additional Reinforcement

- "For sections without fins: Attach center hinges to all other pre-punched locations using (2) 1/4" x 3/4" self drilling screws for each hinge (Fig TBA).
- For sections with fins: Attach center hinges to all other pre-punched locations using (2) 1/4" x 5/8" hex head bolts and (2) 1/4" nuts. (Fig TBA).
- If needed, use the pre-punched aluminum angle as a guide to mark and drill 1/4" holes at each center hinge location.
- Install aluminum angle at the same time as center hinges using the same 1/4" x 3/4" bolts that attach the hinge to the top rail fin (Fig. 7-F).
- Drill 1/4" holes through the top rail fin and the aluminum angle at each section end.
- Attach the ends of the aluminum angle to the top rail fin at each end of the section using 1/4" x 5/8" bolts and 1/4" flange nuts (Fig. 7-G).

NOTE: Doors installed in high windload regions (Florida and other high wind prone areas) may require additional reinforcement beyond what is detailed in these instructions. Please refer to approved windload drawings for these areas.

Step 7-6: Install Step Plate

- Install inside step plate to bottom rail nearest the center of the door of the section using (2) 1/4" x 3/4" self drilling screws (Fig. 7-H).

NOTE: Cut out templates on Pages 11 and 12; instructions are continued on Page 13.

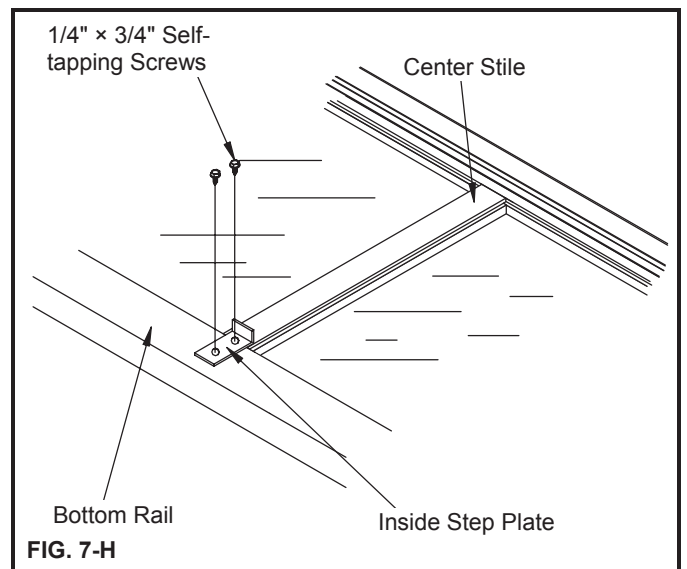
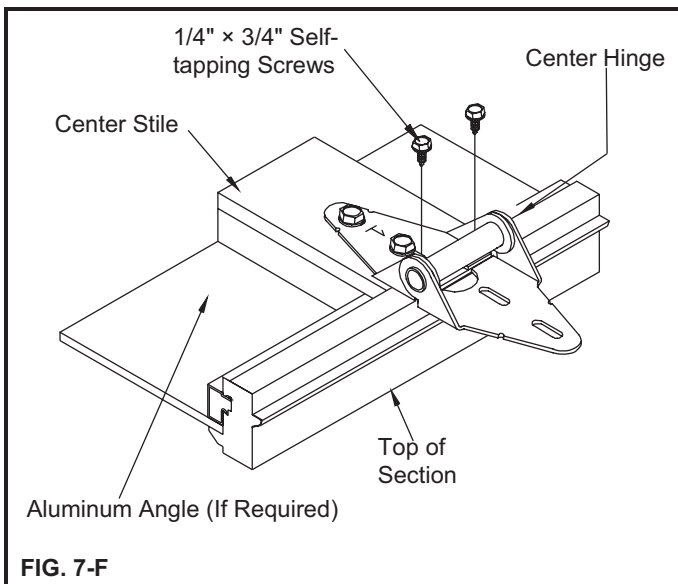
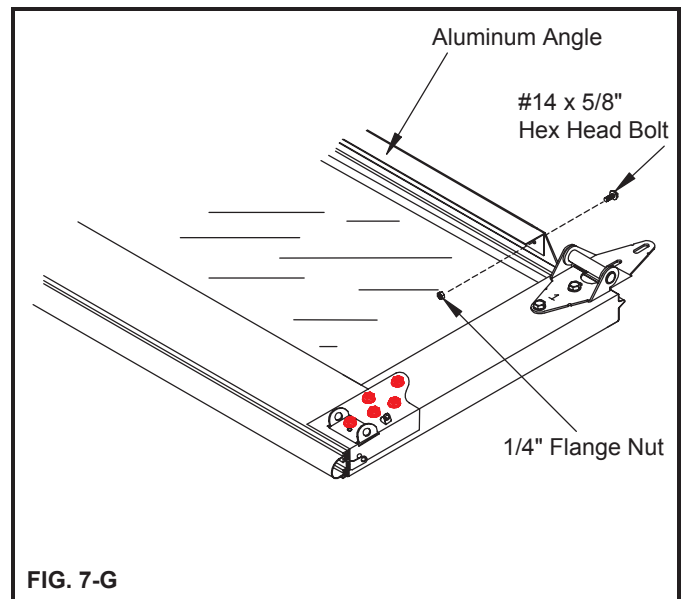
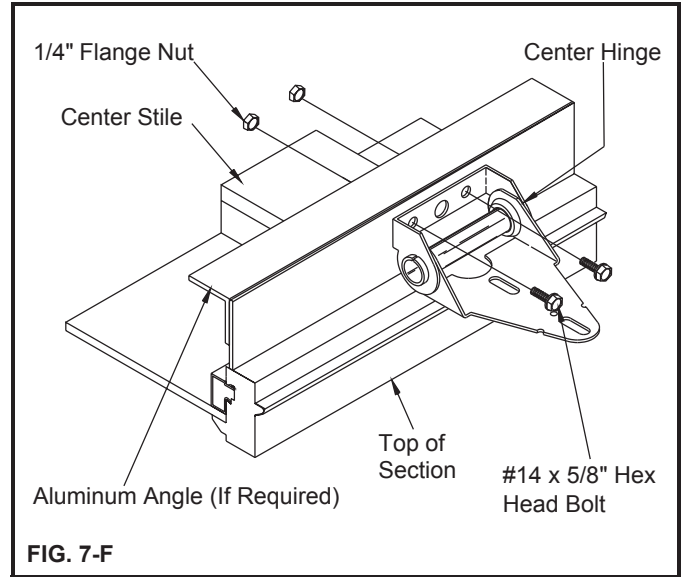

STEP 8 - INSTALL LIFT HANDLES

Outside Lift Handle Template

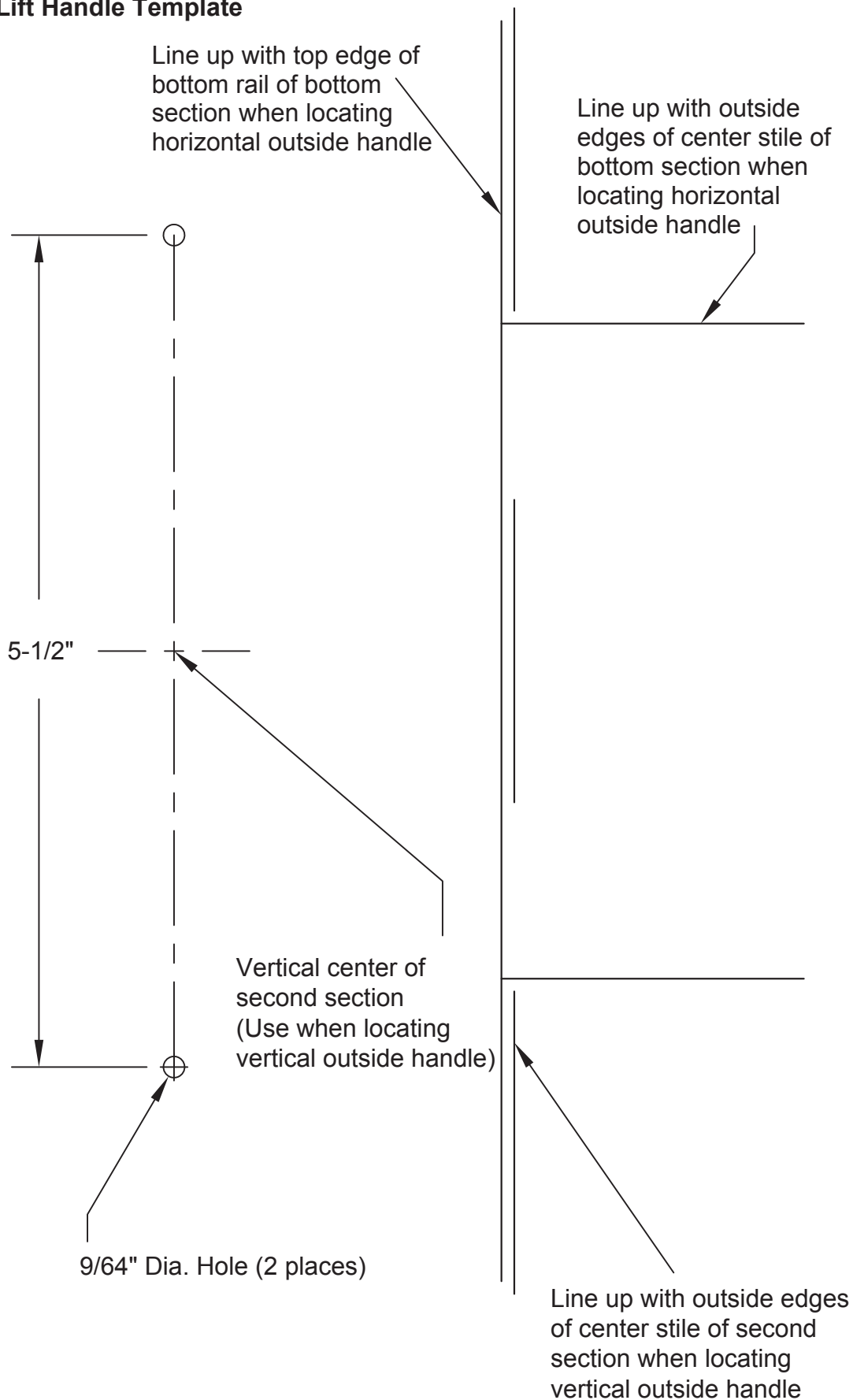

Cut Along Line

STEP 8 - INSTALL LIFT HANDLES

Template and Handle Hole Locations

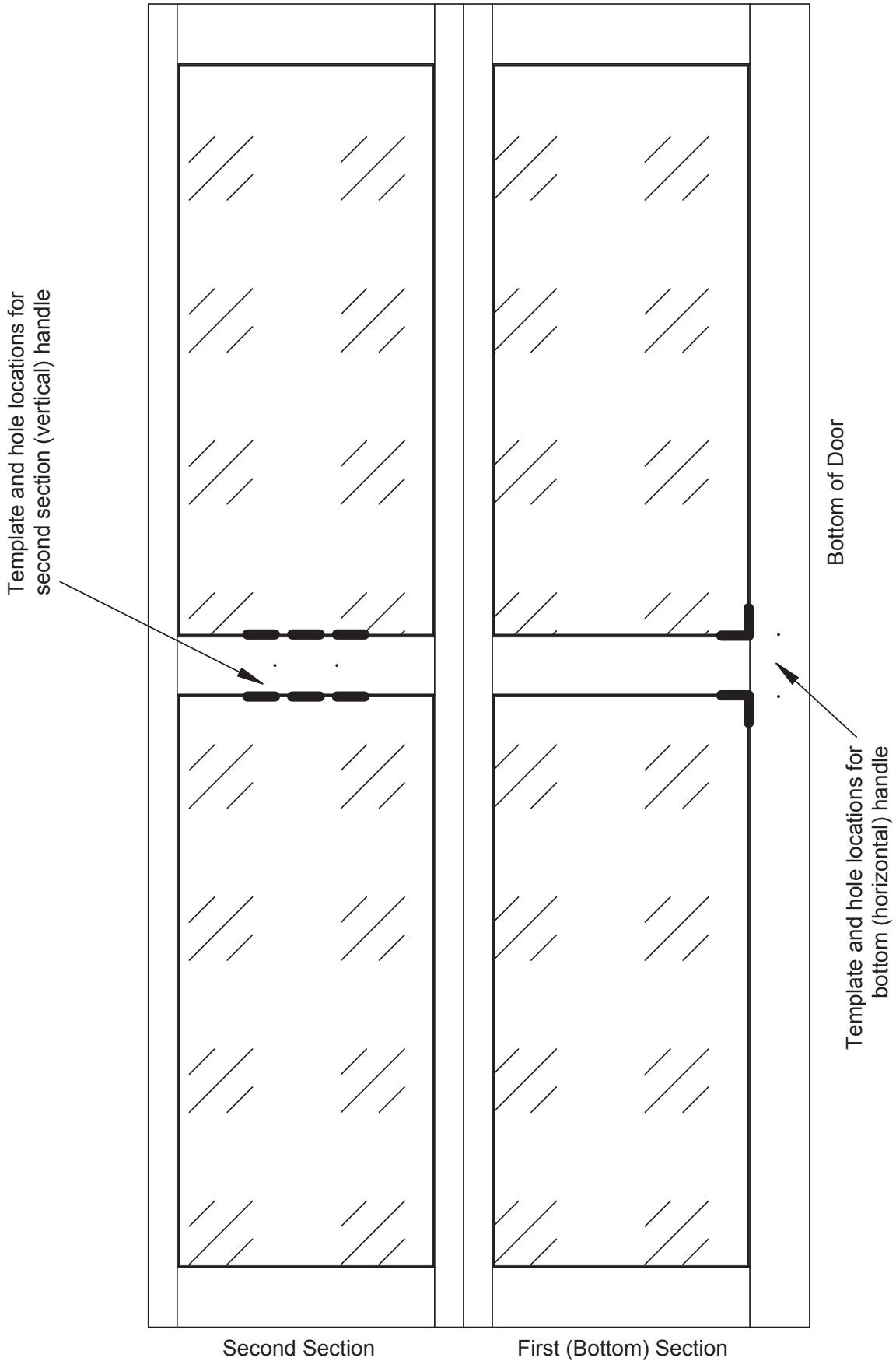

STEP 8 - INSTALL LIFT HANDLES

Step 8-1: First (Bottom) Section

- From the front side of the bottom section, use template provided on Page 11 to mark (2) 9/64" holes in the bottom rail. **DO NOT** drill all the way through the door section.
- Using a Phillips head screwdriver, install (2) handle studs at drilled hole locations using (2) #10 × 1" pan head sheet metal screws (Fig. 8-A).
- Place outside lift handle over handle studs (Fig. 8-B).
- Use a 3/32" Allen wrench to attach outside lift handle to studs using 3/16" set screws (Fig. 8-C).

Step 8-2: Second Section (To Be Installed at the Completion of Step 9-5).

- From the front side of the second section, use template provided on Page 11 to mark (2) 9/64" holes through center stile. **DO NOT** drill all the way through the door section.
- Using a Phillips head screwdriver, install (2) handle studs at drilled hole locations using (2) #10 × 1" pan head sheet metal screws (Fig. 8-A).
- Place outside lift handle over handle studs (Fig. 8-B).
- Use a 3/32" Allen wrench to attach outside lift handle to studs using 3/16" set screws (Fig. 8-C).

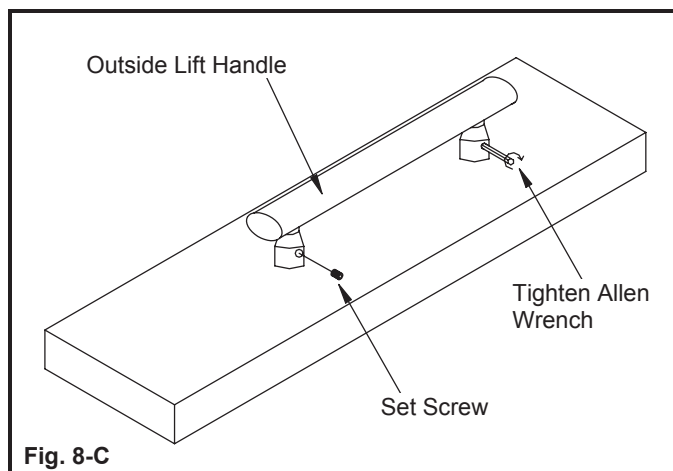
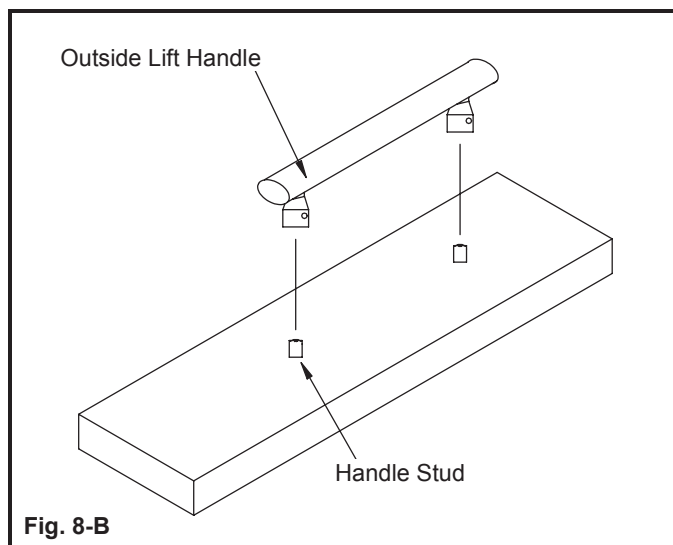
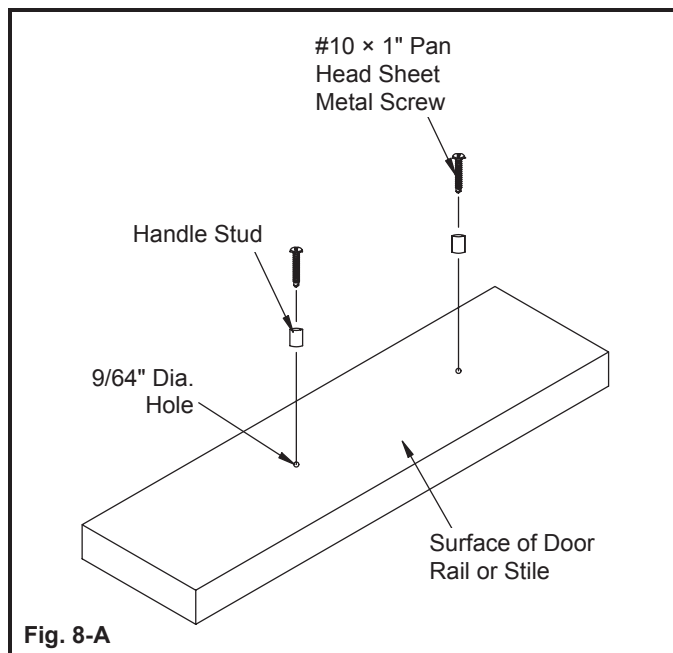

STEP 9 – INSTALLING DOOR SECTIONS

Step 9-1: Place and Secure First (Bottom) Section

- Place First Section in opening against stop molding and center it from side to side.
- Place a level on section. If necessary, use wood shim under one end to make section level (Fig. 9-A).
- Once section is level, remove level and drive a 10d 3" nail in jambs at each section end. Bend over edge to hold section in place (Fig. 9-B).

NOTE: These nails are all that will hold the stacked door section in place until racks are secured to back jambs. Be sure nails hold sections firmly in position.

Step 9-2: Determine Stacking Order for Remaining Sections Using Table 9-A

Table 9-A - Section Order for Various Door Heights

Door Height	Section #							
	1 (BTM)	2	3	4	5	6	7	8
6' 0"	24.750	22.500	24.750					
6' 3"	22.125	16.875	16.875	19.125				
6' 6"	22.125	16.875	16.875	22.125				
6' 9"	22.125	19.875	16.875	22.125				
7' 0"	22.125	19.875	19.875	22.125				
7' 3"	25.125	19.875	19.875	22.125				
7' 6"	25.125	19.875	19.875	25.125				
7' 9"	25.125	22.875	19.875	25.125				
8' 0"	25.125	22.875	22.875	25.125				
8' 3"	22.375	20.125	17.125	17.125	22.375			
8' 6"	22.375	20.125	20.125	17.125	22.375			
8' 9"	22.375	20.125	20.125	20.125	22.375			
9' 0"	25.375	20.125	20.125	20.125	22.375			
9' 3"	25.375	20.125	20.125	20.125	25.375			
9' 6"	25.375	23.125	20.125	20.125	25.375			
9' 9"	25.375	23.125	23.125	20.125	25.375			
10' 0"	25.375	23.125	23.125	23.125	25.375			
10' 3"	22.500	20.250	20.250	20.250	17.250	22.500		
10' 6"	22.500	20.250	20.250	20.250	20.250	22.500		
10' 9"	25.500	20.250	20.250	20.250	20.250	22.500		
11' 0"	25.500	20.250	20.250	20.250	20.250	25.500		
11' 3"	25.500	23.250	20.250	20.250	20.250	25.500		
11' 6"	25.500	23.250	23.250	20.250	20.250	25.500		
11' 9"	25.500	23.250	23.250	23.250	20.250	25.500		
12' 0"	25.500	23.250	23.250	23.250	23.250	25.500		
12' 3"	22.625	20.375	20.375	20.375	20.375	20.375	22.625	
12' 6"	25.625	20.375	20.375	20.375	20.375	20.375	22.625	
12' 9"	25.625	20.375	20.375	20.375	20.375	20.375	25.625	
13' 0"	25.625	23.375	20.375	20.375	20.375	20.375	25.625	
13' 3"	25.625	23.375	23.375	20.375	20.375	20.375	25.625	
13' 6"	25.625	23.375	23.375	23.375	20.375	20.375	25.625	
13' 9"	25.625	23.375	23.375	23.375	23.375	20.375	25.625	
14' 0"	25.625	23.375	23.375	23.375	23.375	23.375	25.625	
14' 3"	25.688	20.438	20.438	20.438	20.438	20.438	22.688	
14' 6"	25.688	20.438	20.438	20.438	20.438	20.438	25.688	
14' 9"	25.688	23.438	20.438	20.438	20.438	20.438	25.688	
15' 0"	25.688	23.438	23.438	20.438	20.438	20.438	25.688	
15' 3"	25.688	23.438	23.438	23.438	20.438	20.438	25.688	
15' 6"	25.688	23.438	23.438	23.438	23.438	20.438	25.688	
15' 9"	25.688	23.438	23.438	23.438	23.438	20.438	25.688	
16' 0"	25.688	23.438	23.438	23.438	23.438	23.438	25.688	

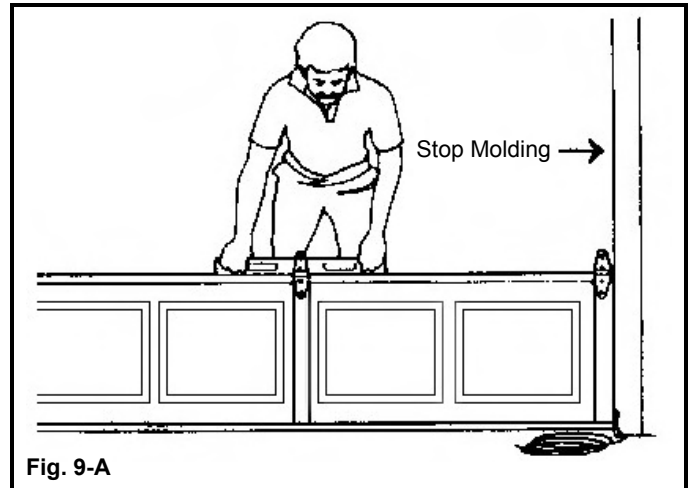

Fig. 9-A

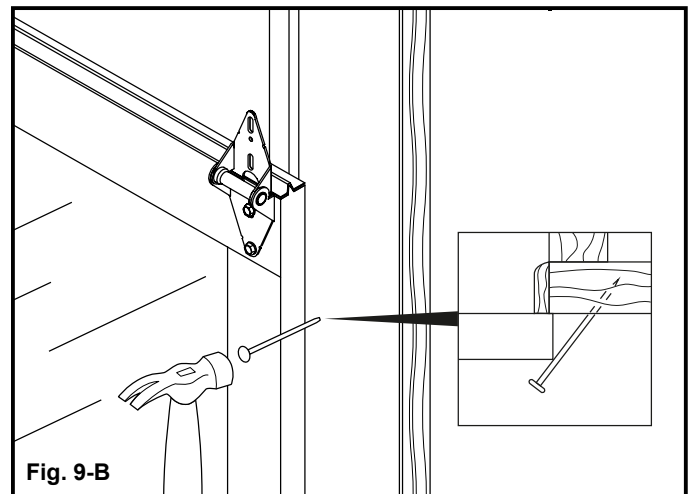

Fig. 9-B

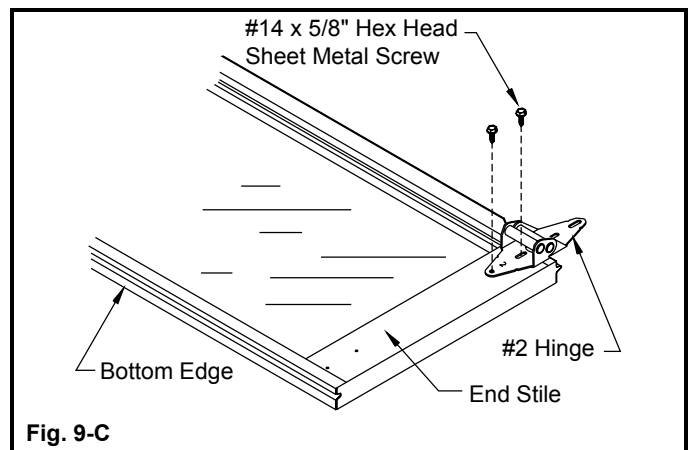

Fig. 9-C

STEP 9 – INSTALLING DOOR SECTIONS

Step 9-3: Prepare Second (Lock) Section

- Place section face down on covered sawhorses.
- For sections without fins: Attach center hinges to all other pre-punched locations using (2) 1/4" x 3/4" self drilling screws for each hinge (Fig 7-F).
- For sections without fins: Attach center hinges to all other pre-punched locations using (2) 1/4" x 3/4" self drilling screws for each hinge (Fig 7-F).
- For sections with fins: Attach center hinges to all other pre-punched locations using (2) 1/4" x 5/8" hex head bolts and (2) 1/4" nuts (Fig 7-F).

NOTE: If this section requires an aluminum angle, install it now (Step 7-5).

- Install lift handle as shown on Page 13 if door did not come with a lock (Fig. 8-B).

NOTE: If you wish to install a keyed lock, begin lock installation now according to supplemental instructions included with lock hardware.

CAUTION

Take care not to bend or twist sections with glass as this may cause glass to break, which may result in personal injury.

Step 9-4: Place and Secure Second (Lock) Section

- Place second section in opening on top of first section.
- Drive a 10d 3" nail in jambs at each section end. Bend over edge to hold section in place.
- Attach hinges from top of first section to bottom of second section using (2) #14 x 5/8" hex head sheet metal screws for each hinge (Fig. 9-E).

Step 9-5: Prepare Next (Third) Section

- Third section has the general safety label applied (Fig. 9-D).
- Place section face down on covered sawhorses.
- Attach a #3 hinge at each end at top edge using (2) #14 x 5/8" hex head sheet metal screws (Fig. 9-C).
- For sections without fins: Attach center hinges to all other pre-punched locations using (2) 1/4" x 3/4" self drilling screws for each hinge (Fig 7-F).
- For sections with fins: Attach center hinges to all other pre-punched locations using (2) 1/4" x 5/8" hex head bolts and (2) 1/4" nuts. (Fig 7-F).

NOTE: If this section requires an aluminum angle, install it now (STEP 7-5).

Step 9-6: Place and Secure Second (Lock) Section

- Place third section in opening on top of second section.
- Drive a 10d 3" nail in jambs at each section end. Bend over edge to hold section in place.
- Attach hinges from top of first section to bottom of second section using (2) #14 x 5/8" hex head sheet metal screws for each hinge (Fig. 9-E).
- If you have multiple sections left, repeat Steps 9-5 and 9-6 using #4 or higher hinges on the ends and center hinges at all other hinge locations.

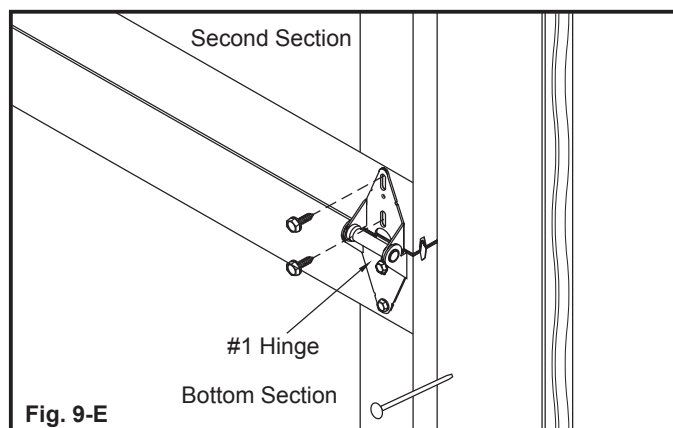
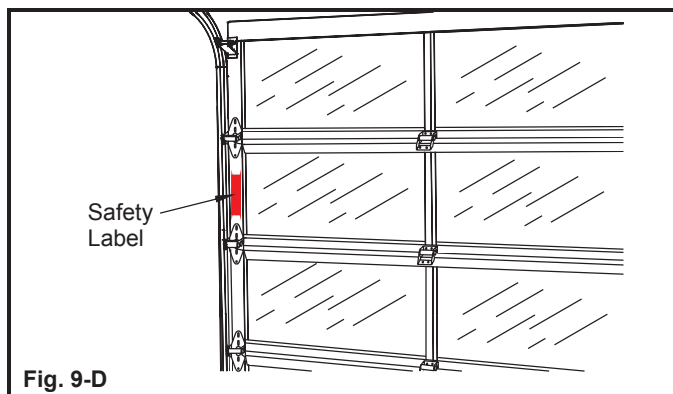

STEP 9 – INSTALLING DOOR SECTIONS

Step 9-7: Prepare Last (Top) Section

- Place section face down on covered sawhorses.
- Attach top brackets at each end of top edge using (2) 1/4" × 3/4" self-drilling screws for each bracket. The bottom of the bracket should be at 6-1/4" down from the top of section. (Fig 9-F for standard lift doors, Fig. 9-G for low headroom doors.)

Step 9-8: Place and Secure Last (Top) Section

- Place last section in opening on top of previous section.
- Drive a 10d 3" nail in jambs at each section end. Bend over edge to hold section in place.
- Attach hinges from top of previous section to bottom of this section using (2) 1/4" × 3/4" self-tapping screws for each hinge (Fig. 9-E).

NOTE: If your door is to be used with an electric operator, you must reinforce the top section before placing it in the opening. Proceed to STEP 10 prior to completing this step.

Step 9-9: Place Rollers

- Place a roller in the top and bottom bracket and in the tubes in each of the hinges at the ends of each installed section. Long stem rollers go in the bottom brackets on the first section.

NOTE: In hinges with two tubes, place roller in tube farthest from door face (Fig. 9-H).

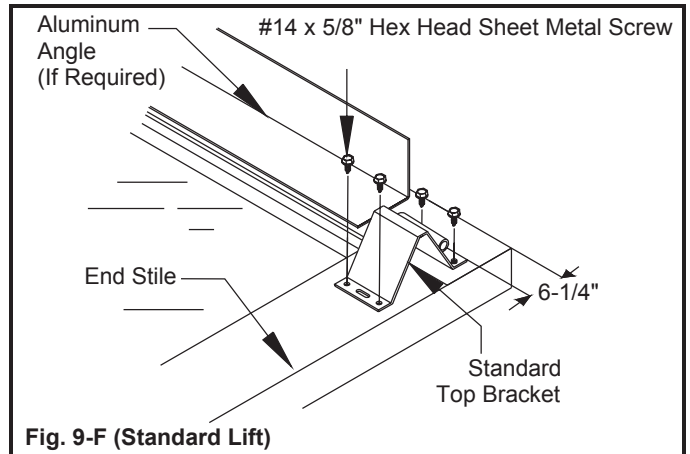

Fig. 9-F (Standard Lift)

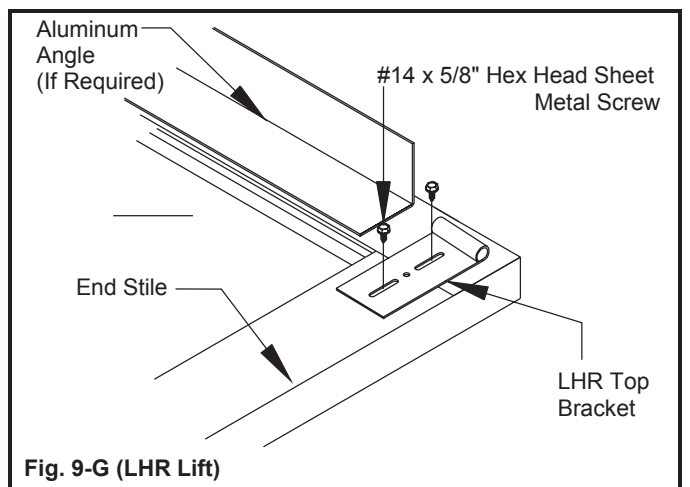

Fig. 9-G (LHR Lift)

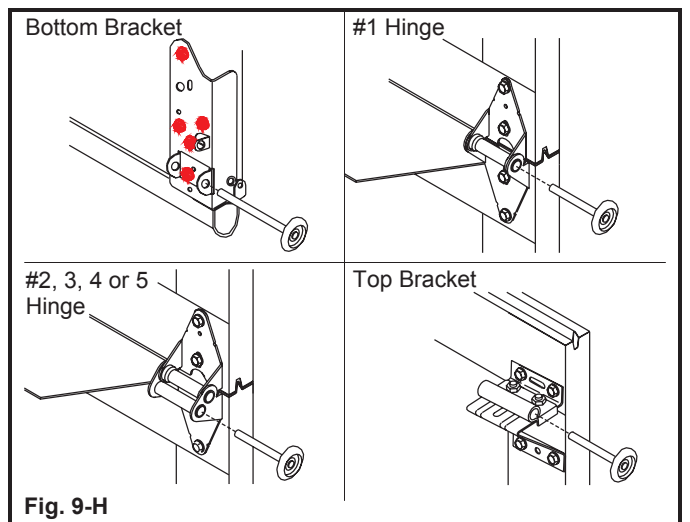

Fig. 9-H

STEP 10 – REINFORCING THE TOP SECTION

NOTE: To avoid damage to door, you **MUST** reinforce top section of door in order to provide a mounting point for opener to be attached.

⚠ WARNING

DO NOT install the bracket supplied with opener. Failure to reinforce door, as illustrated, will void door warranty.

Step 10-1: Reinforce Top Section

- You will need (1), (2) or (3) pieces of 1-1/4" × 1-1/4" minimum punched angle at least 13 gauge or 3/32" thick.
- Determine how punched angle is to be affixed to your door size (Fig. 10-A through 10-D). Angle iron may need to be trimmed depending on door section height and distance between center stiles.

NOTE: An opener bracket kit specifically designed for opener attachment may be included or purchased (silver galvanized or white powder coated). Instructions are provided with the kit.

NOTE: Operator may be attached up to 2 feet off center. (Doors with torsion springs only.)

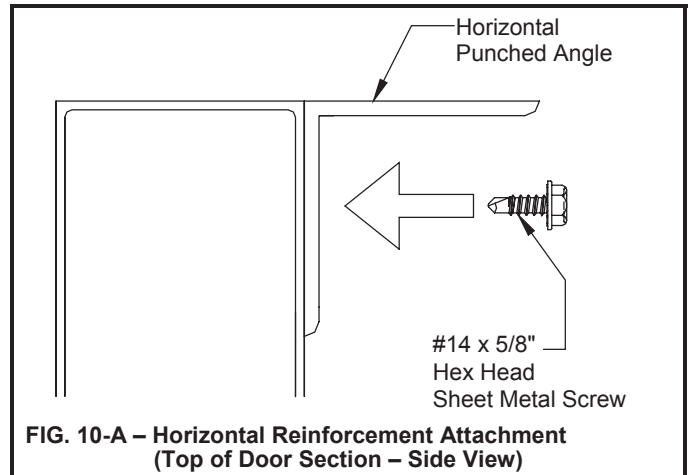

FIG. 10-A – Horizontal Reinforcement Attachment (Top of Door Section – Side View)

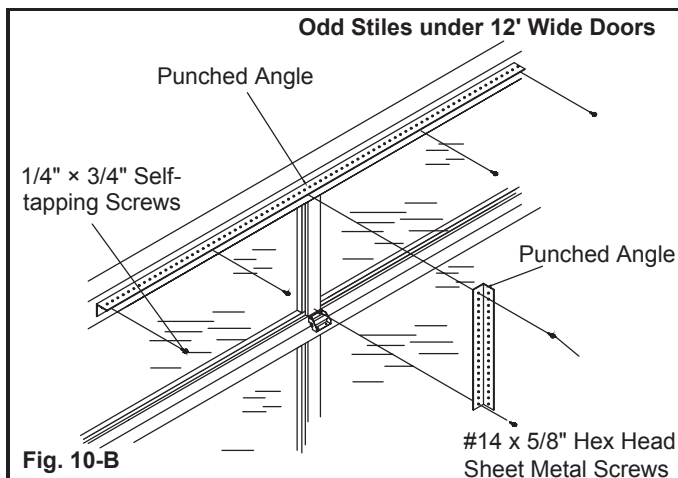

Fig. 10-B

Required materials:
 (1) 18", 21" or 24" and (1) 48" length of iron
 (6) #14 x 5/8" hex head sheet metal screws

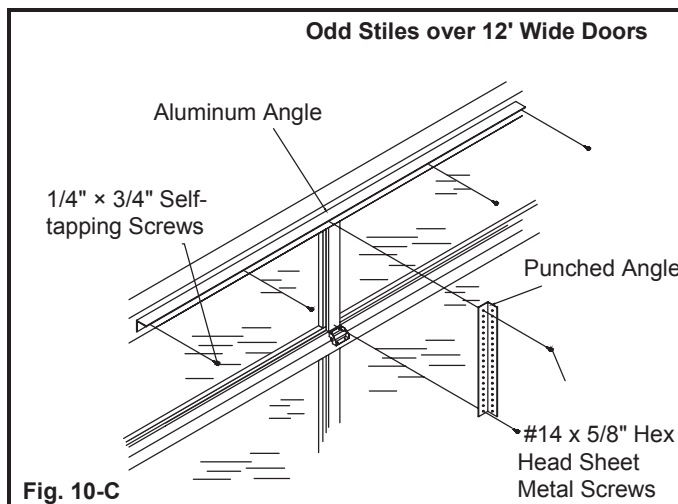

Fig. 10-C

Required materials:
 (1) 18", 21" or 24" length of iron and (1) 48" aluminum angle
 (6) #14 x 5/8" hex head sheet metal screws

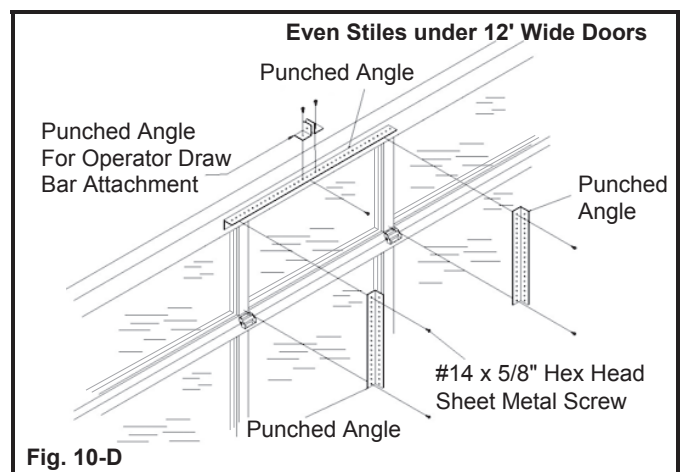

Fig. 10-D

Required materials:
 (2) 18", 21" or 24" and (1) 27" or 50" length of iron
 (5) #14 x 5/8" hex head sheet metal screws
 (2) 1/4" x 3/4" bolts and nuts

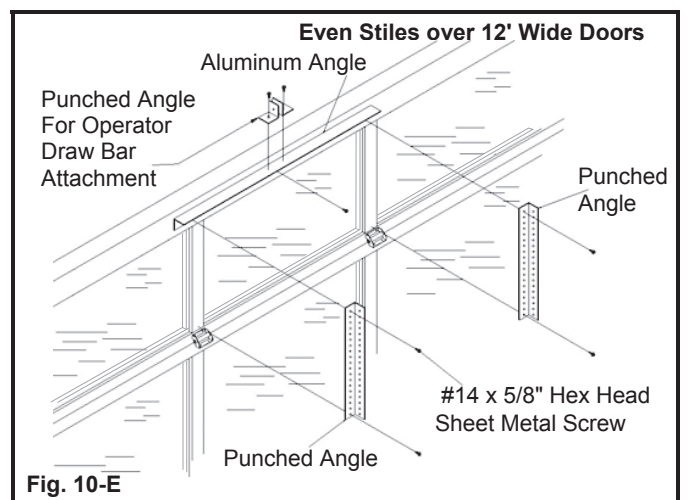

Fig. 10-E

Required materials:
 (2) 18", 21" or 24" length of iron and (1) 27" or 50" aluminum angle
 (5) #14 x 5/8" hex head sheet metal screw
 (2) 1/4" x 3/4" bolts and nuts

STEP 11 - ASSEMBLE AND INSTALL THE TRACK

Before assembling brackets to vertical track, be sure to read Steps 11-1 and 11-2 (Fig. 11-B) for placement of brackets on track.

NOTE: Brackets may already be riveted in place. If additional adjustment is required, rivets can be drilled out and brackets reattached with track bolts and flange nuts (available through toll-free Clopay Consumer Services, see front).

WARNING

Failure to use the track provided with new door may cause installation problems or the door to fall which could result in serious injury or property damage.

WARNING

DO NOT attach any brackets directly to drywall. All track brackets, flag brackets and spring brackets should be attached directly only to wood bucks.

Step 11-1: Assemble Track Brackets to Vertical Track

- There are two sizes of track brackets for 7' tall doors and three sizes for 8' tall doors. Each bracket should be installed with flange facing flat side of track and flat side toward wall (Fig. 11-A).
- Loosely fasten horizontal slot of track brackets to vertical track using (1) $1/4" \times 5/8"$ track bolt and (1) $1/4"$ flange nut. Head of bolt faces inside track. Brackets should be installed on vertical track as follows (Fig. 11-C):
 - Shortest pair — 10" from bottom of track
 - Next longest pair — centered on track
 - For 8' tall doors — install remaining pair 10" from top of track

Step 11-2: Assemble Flag Brackets to Vertical Track

- Determine proper holes in flag bracket for door thickness (Fig. 11-B).
- Loosely attach flag bracket to top of track with (2) $1/4" \times 5/8"$ track bolts and $1/4"$ flange nuts. Head of bolts face inside track.

NOTE: If additional adjustment is required, horizontal slots in flag brackets can be used for attachment to vertical track.

Step 11-3: Place Vertical Track into Position

- Place track over rollers on door.
- Move track close to door so rollers are all the way into hinges leaving about $1/2"$ between edge of door and edge of track.

NOTE: Do not force track too tightly or door will bind.

- Lift track about $1/2"$ from floor and mark jamb for each lag screw position.

NOTE: Do not raise vertical track beyond bottom rollers on bottom section of door.

- Drill $3/16"$ pilot holes at each lag screw location. Fasten flag bracket to jamb using (3) $5/16" \times 1-5/8"$ lag screws, one in each of top, middle and bottom holes. Repeat on opposite side.
- Once flag brackets are securely fastened to jamb, tighten track bolts and flange nuts connecting flag brackets to tracks (Fig. 11-D).

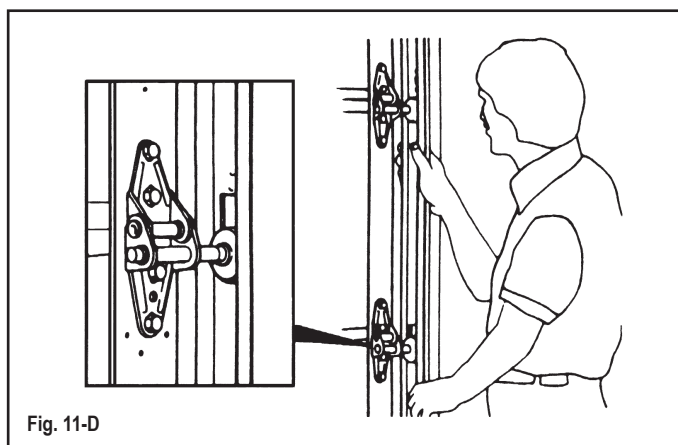
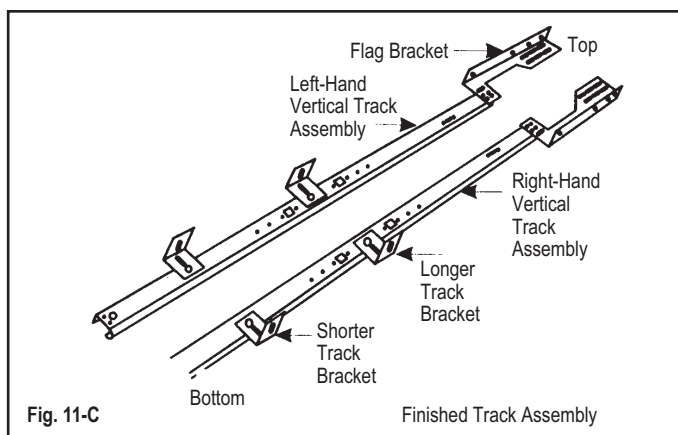
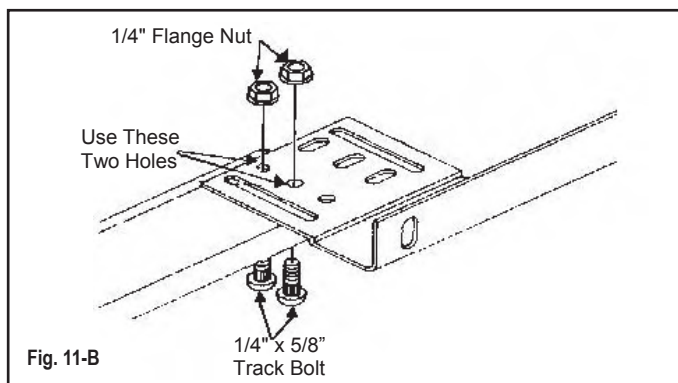
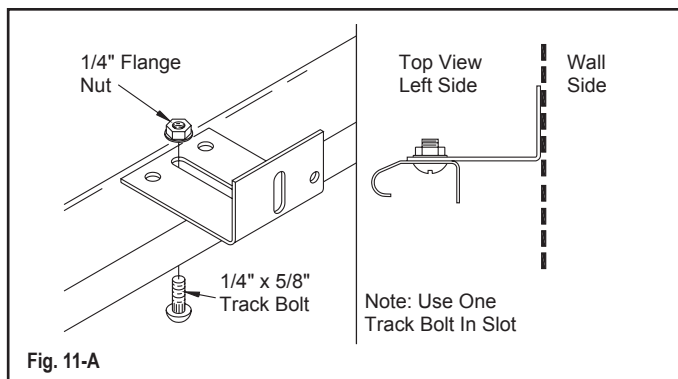

STEP 11 - ASSEMBLE AND INSTALL THE TRACK

NOTE: The tops of vertical tracks must be level with each other. Check this by measuring from top of door sections to top of track on both sides. If they are not equal, cut material off bottom of one track to lower it or raise other track.

NOTE: Pressure-treated lumber purchased after January 2004 is treated with chemicals that have highly corrosive effects on metal fasteners. Fasteners provided with door are intended for use with standard lumber (not pressure-treated) only. If installing door into an opening framed with pressure-treated lumber, it is highly recommended that 5/16" x 1-5/8" lag screws with a minimum galvanization equivalent of G185 be purchased for this application.

Step 11-4: Assemble Flag Brackets to Vertical Track

NOTE: On some doors this angle may be 82" long and will require (3) additional fasteners per side. If angle has been preassembled, skip Step 12-4 and proceed with Step 12-5.

- Fasten horizontal angle to horizontal (curved) track using (2) 1/4" x 5/8" track bolts and (2) 1/4" flange nuts. Head of bolt faces inside track (Fig. 11-E).

Step 11-5: Support Rear End of Track

- Temporarily support rear end of track with a rope tied to trusses overhead in garage or resting on tall ladder (Fig. 11-F).

Step 11-6: Assemble Horizontal Track to Flag Bracket

- Place curved end of horizontal track over roller in top bracket.
- Attach track to flag bracket using (2) 1/4" x 5/8" track bolts and (2) 1/4" flange nuts. Head of bolt faces inside track.

NOTE: Horizontal and vertical track must join together to form a continuous channel for rollers.

- Attach end of horizontal angle to top of flag bracket with a 3/8" x 3/4" carriage bolt and 3/8" hex nut (Fig. 11-G).
 - For 15" radius track use top set of slots
 - For 12" radius track use middle set of slots
 - For low headroom track use bottom set of slots

Step 11-7: Assemble Rear Track Hangers

NOTE: Rear track hangers are not provided with standard hardware and will need to be made at this time. They are used to attach rear horizontal track to ceiling joist and must be strong enough to hold full weight of door.

WARNING

Sway braces must be used to prevent tracks from spreading and allowing door to fall, which could cause serious injury. Bolts placed in end of each track (Fig. 11-H) must be at least 1" long to prevent top section from exiting track.

- Use 1-1/4" x 1-1/4" punched angle, at least 13 gauge or 3/32" steel to make two rear track hangers with sway braces (Fig. 11-H).
- Attach to track using at least 1" long bolts (Fig. 11-H).

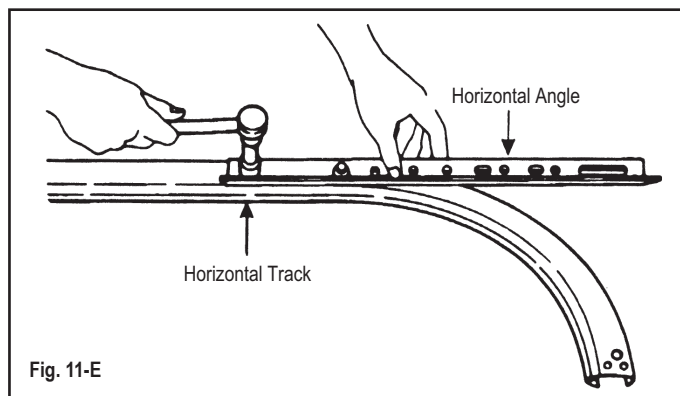

Fig. 11-E

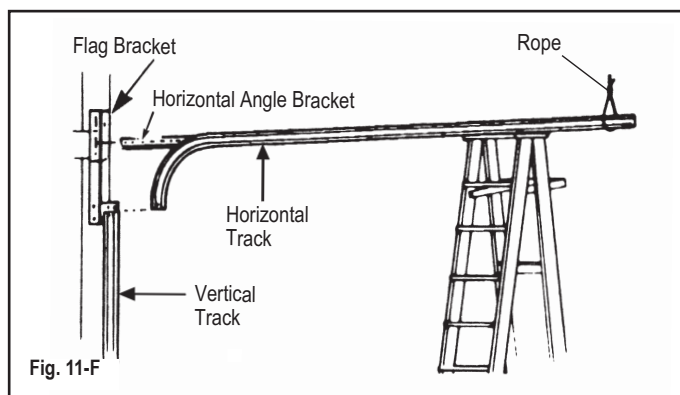

Fig. 11-F

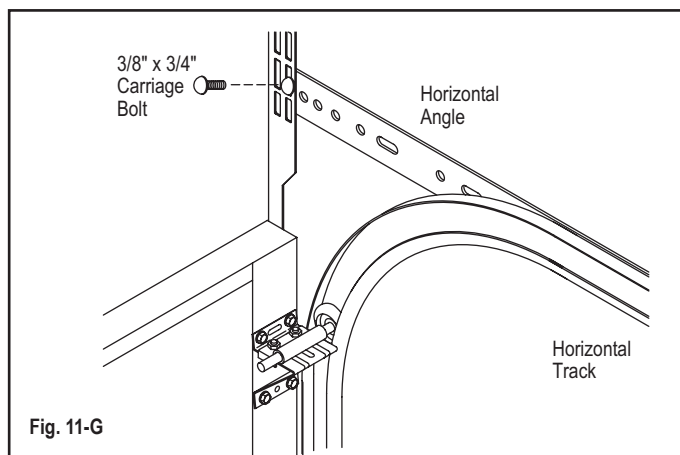

Fig. 11-G

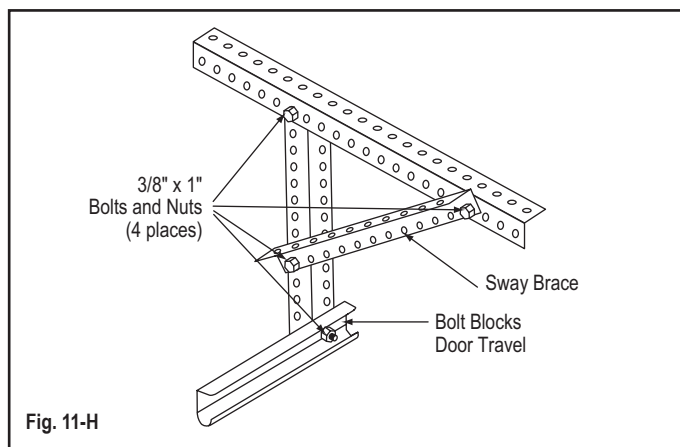

Fig. 11-H

STEP 11 - ASSEMBLE AND INSTALL THE TRACK

Step 11-8: Placement of Rear Track Hangers

Placement of rear track hangers is critical for door to operate properly. They should not be mounted any farther than 6" from end of horizontal track and should hold horizontal track level and square to door.

- Squareness should be measured by comparing two diagonal distances (Fig. 11-I):
 - 1) From top left-hand corner of door to rear of right-hand horizontal track.
 - 2) From top right-hand corner of door to rear of left-hand horizontal track.
- Squareness distances should be within 1/2" of each other. Horizontal track can be out of level up to 1" from front jamb to rear track hanger (Fig. 11-I).
- With track square and level with opening, track hangers can be fastened permanently to ceiling trusses using (3) 5/16" × 1-1/2" lag screws. Drill 3/16" pilot holes before installing 5/16" lag screws.

⚠ WARNING

To prevent door from falling and causing serious injury, be sure rear track hangers are properly secured to trusses with adequate length screws.

Step 11-9: Adjust Top Section

- With track installed, top door section can now be properly adjusted.
- Loosen slide on top bracket and push top of door against stop molding or door jamb. Pull roller toward you so it is tight against the groove in track.
- Tighten slide bolts (Fig. 11-J).
- Remove all 10d 3" nails holding all sections in place.

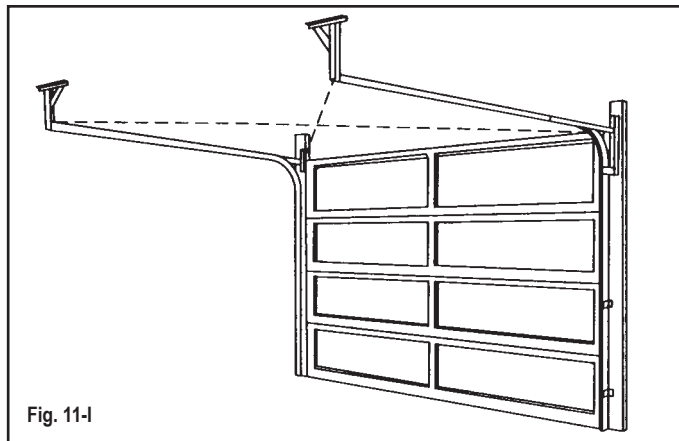

Fig. 11-I

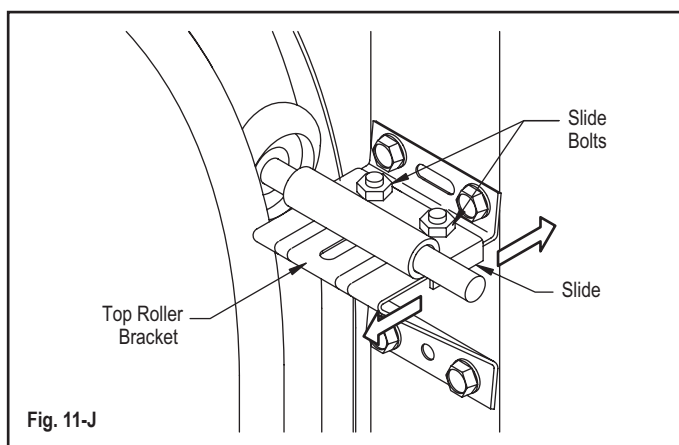

Fig. 11-J

STEP 12 - INSTALL LOCK (IF INCLUDED)

If a lock is included with door, follow appropriate instructions below.

Exterior Keyed Lock:

- If door has an exterior keyed lock, complete installation of lock at this time. Follow instructions provided with lock hardware.

Interior Slide Lock:

- Use track as a guide to achieve proper alignment.
- Position slide bolt against top of one of rectangular engaging slots in vertical track.

NOTE: It may be necessary to knock out slug in vertical track to open slot for lock engagement. Remove slug by striking with a hammer from outside of track.

- Install inside slide bolt on the end stile of second section.
Use (4) #14 × 5/8" hex head sheet metal screws (steel doors)
or (4) 1/4" × 1" lag screws (Fig. 12-A).

NOTE: 3/16" holes may need predrilled before installing screws.

IMPORTANT: If door is going to be equipped with an automatic garage door opener, make sure that door is always unlocked when opener is being used. This will avoid damage to door.

#14 x 5/8" Sheet Metal Screw or 1/4" x 1" Lag Screw

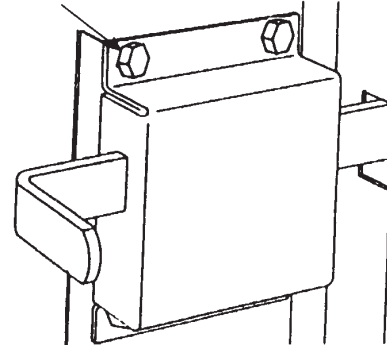

Fig. 12-A

STEP 13 - INSTALL PULL ROPE (MANUALLY OPERATED DOORS ONLY)

NOTE: Rope is only intended for use on manually operated doors.
DO NOT install pull rope if using an automatic garage door opener.

Install Pull Rope for Manually Operated Doors

- Install the pull rope by attaching to roller shaft in bottom bracket of door (Fig. 13-A).

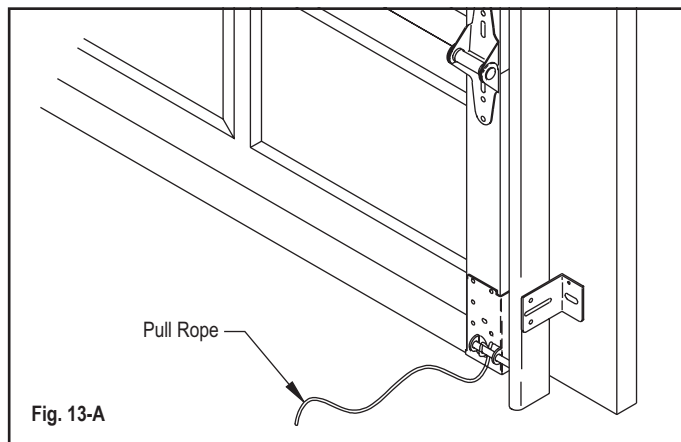

Fig. 13-A

STEP 14 - STANDARD TORSION SPRING INSTALLATION

⚠ WARNING

Torsion springs can be very dangerous if they are improperly installed or mishandled. Do not attempt to install them yourself unless 1) you have the proper tools and reasonable mechanical aptitude or experience and 2) you follow these instructions very carefully. Failure to do so could cause springs or components to break free and cause property damage, or serious injury.

Materials Required for Torsion Spring Installation:

- (2) 9/16" box wrenches
- 7/16" socket wrench
- (2) 1/2" diameter, 18" long cold rolled solid steel winding bars

NOTE: Winding bars are available at most hardware stores.

- Locking pliers
- 2" x 6" wood anchor pad

NOTE: Use (1) wood anchor pad for standard torsion spring installation, (2) wood anchor pads for solid steel shaft torsion spring installation.

Step 14-1: Install End Bearing Plates

- Identify the bottom of the end plate by the two parallel rows of two slots (Fig. 14-A).
- Fasten bottom of end bearing plate to horizontal angle using (2) 3/8" x 3/4" long hex head bolts and hex head nuts. Use the bottom two slots for 12" radius track and the upper two slots for 15" radius track (Fig. 14-A).
- Drill 3/16" pilot holes where lag screws into the wood jamb where lag screws are to be installed.
- Fasten wall flange on the end bearing plate to the wood jamb using (1) 5/16" x 1-5/8" for each bearing plate (Fig. 14-B).

NOTE: For 12" radius track, each end bearing plate should also be attached with 3/8" x 3/4" carriage bolts and 3/8" nuts (Fig. 14-B).

Step 14-2: Install Wood Anchor Pad

⚠ WARNING

Spring anchor bracket secures the springs to the wall. You must fasten securely with red-colored fasteners. Never remove spring anchor bracket when springs are wound.

NOTE: If the door has solid steel shaft in two sections skip to Step 15-1.

- Measure from top of door to end bearing and draw a line at the same height for shaft location over the center of the door.
- Using at least (4) long lag screws for wooden frames (or (4) 3/8" x 4" sleeve anchors for concrete frames), attach a 2" x 6" wood anchor pad to the frame of the garage across the center of door. Fasteners should be installed at each corner of anchor pad, but no closer than 1-1/2" from the edge (Fig. 6-A).

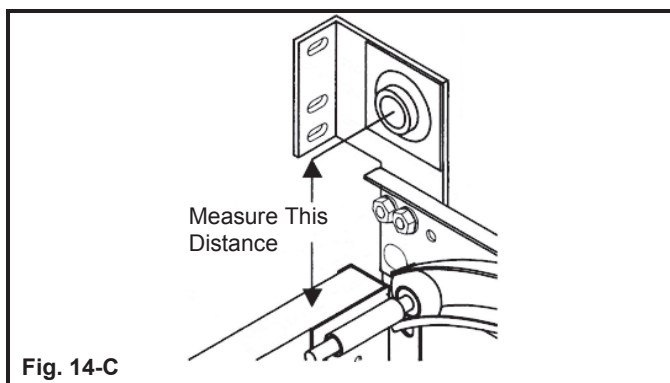
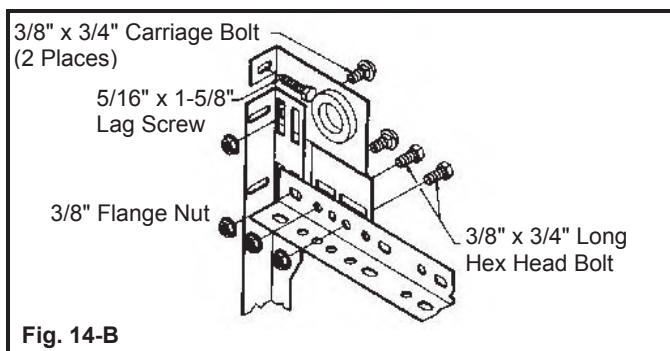
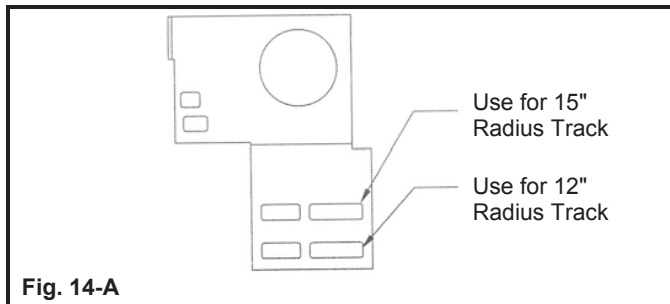

NOTE: Header and side jambs should extend 12" above the top of the opening for 12" radius and 15" above the top of the opening for 15" radius (Fig. 6-A). Wood anchor pad may be off center to width of the opening by up to 10" in either direction.

IMPORTANT: Wood anchor pad must be made of Grade 2 or better southern yellow pine (also known as southern pine or yellow pine), beech, birch, hickory or oak. It must be free of cracks or splits. Do not use spruce pine fir (SPF).

- Do not attach anchor pad to drywall or sheet rock.
- Do not use nails.

STEP 14 - STANDARD TORSION SPRING INSTALLATION

Step 14-3: Lock the Door in Down Position

- Using door lock or locking pliers, lock door in down position securely.

NOTE: Following steps require an assistant. Prior to locking the door be sure you, your assistant, and tools needed are inside the garage.

⚠ WARNING

Lock the door in the down position securely using door lock or locking pliers. This must be done to prevent the door from prematurely opening which could cause an injury.

Step 14-4: Torsion Spring Assembly

- Your door will have either one or two torsion springs, each consisting of spring coils, a stationary cone and a winding cone. You can identify the stationary cone as a flange with two holes (Fig. 14-D).
- When looking from inside the garage out, the stationary cone will be facing toward the center bearing plate in the center of the door. The winding cones will be facing the outside of the door (Fig. 14-E).

⚠ WARNING

Failure to install torsion springs on the correct side will cause your door to function improperly and could result in property damage or serious injury.

NOTE: If your door has low headroom front mount spring setup, skip to Step 16-1.

- Slide the torsion spring(s), steel center bearing and center bearing plate onto the spring tube.
- Next, slide the cable drums on the outside of the spring tube.
- From left to right, inside the garage facing out, parts should be: left drum, left side spring (right wound) with stationary cones facing the center of the door, steel center bearing, center bearing plate, right side spring (left wound) with stationary cones facing the center of the door, right drum (Fig. 14-E).

Step 14-5: Mount Spring Assembly to Wall

- With an assistant, lift the complete torsion spring tube assembly and slide ends of tube into bearings on the end bearing plates.
- Check to make sure the tube is level and aligns with the mark drawn previously for the spring anchor pad.
- Drill (2) 3/16" pilot holes into spring anchor pad, no closer than 1-1/2" from edge.
- Mount the center bearing plate to center anchor pad using (2) 5/16" × 1-5/8" red-headed lag screws.
- Connect spring(s) to center bearing plate. Use (2) 3/8" × 1" hex bolts and nuts for single springs or (2) 3/8" × 1-5/8" hex bolts and nuts for double springs (Fig. 14-F).

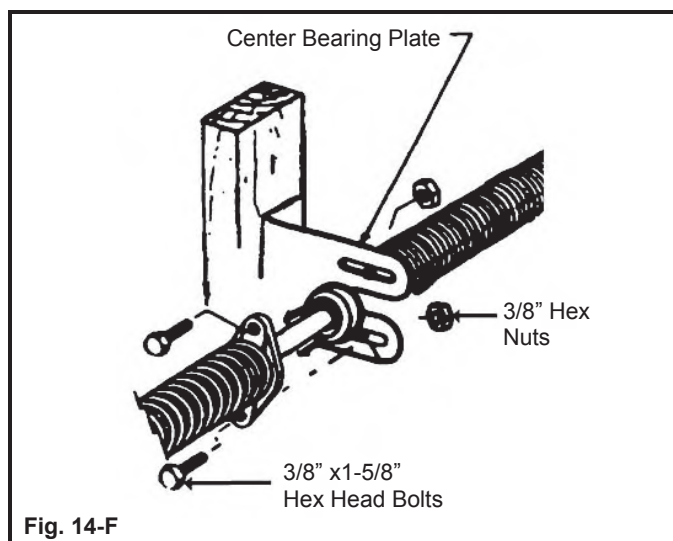
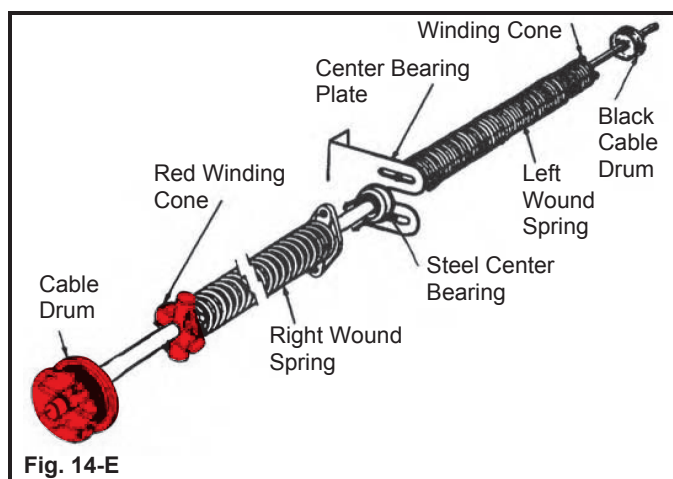
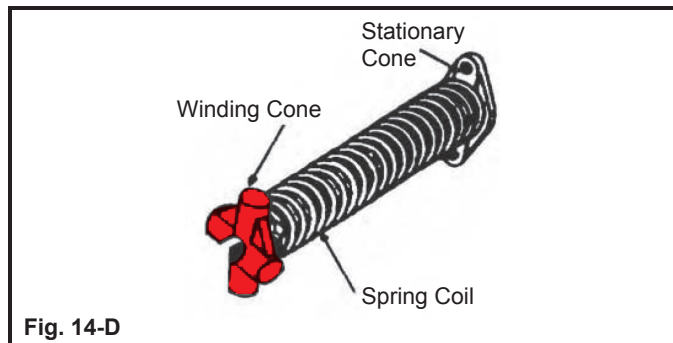

STEP 14 - STANDARD TORSION SPRING INSTALLATION

Step 14-6: Attach Lift Cables

- Bring up left side cable (inside garage looking out) between wall and roller shafts to cable drum.
- Attach cable by placing in notch on cable drum.
- Turn drum by hand and slide cable up tight against end bearing plate to remove cable slack. Be sure cable follows grooves in cable drum.
- While holding cable taught, tighten set screws on cable drum using 3/8" box wrench.

CAUTION

Set screws should only be turned from 3/4 to one full turn after they have made contact with tube.

- Clamp locking pliers on torsion spring tube to maintain tension on cable.
- Repeat cable attachment for the right side.

Step 14-7a: Wind Torsion Springs

If installing low headroom front mount springs skip to Step 16-1.

- Check for a straight line drawn across the length of the spring(s). Draw a line using chalk if none is present. This will indicate the number of turns on the spring(s).
- Insert the two cold rolled steel winding bars all the way into the winding cone.
- With a firm grip on the winding bars, wind the springs 1/4 turn at a time in the upward direction (Fig. 14-G). Use Table 14-7 Winding Chart to determine how many winds for your door height.

Door Height	Spring Turns
6'0"	6.75
6'3"	7.00
6'6"	7.25
6'9"	7.50
7'0"	7.75
7'3"	8.00
7'6"	8.25
7'9"	8.50
8'0"	8.75

*For doors over 8'0" see the spring label.

- Secure each spring with the set screws in the winding cone once the full amount of winds is achieved.

CAUTION

Set screws should only be turned from 3/4 to one full turn after they have made contact with tube.

- Repeat for second spring if applicable. Each spring should be wound the same number of times.
- Remove locking pliers.

NOTE: Springs should increase in tension as turns are added. If they do not, you may have the springs reversed.

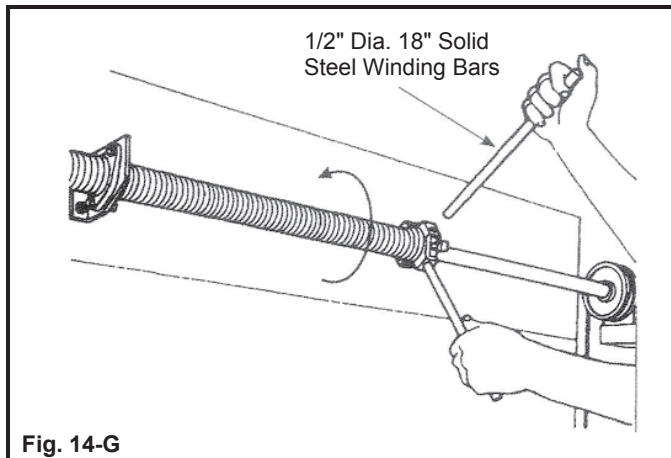

Fig. 14-G

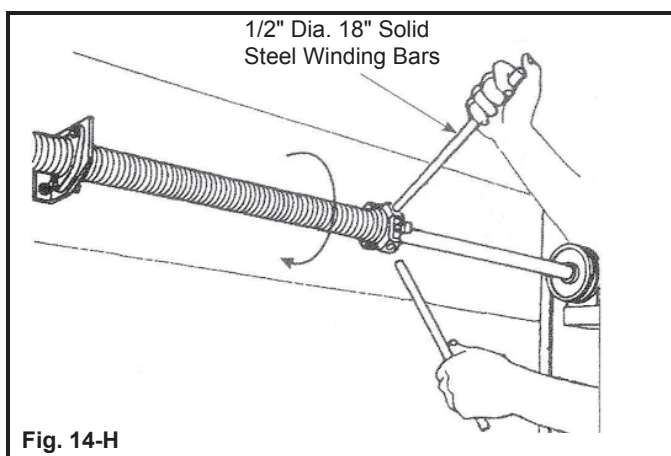

Fig. 14-H

Step 14-7b: Wind Torsion Spring for Front Mount Low Headroom

- Check for a straight line drawn across the length of the spring(s). Draw a line using chalk if none is present. This will indicate the number of turns on the spring(s).
- Insert the two cold rolled steel winding bars all the way into the winding cone.
- With a firm grip on the winding bars, wind the springs 1/4 turn at a time in the **downward** direction (Fig. 14-H). Use Table 14-7 Winding Chart to determine how many winds for your door height.
- Secure each spring with the set screws in the winding cone once the full amount of winds is achieved.

CAUTION

Set screws should only be turned from 3/4 to one full turn after they have made contact with tube.

- Repeat for second spring if applicable. Each spring should be wound the same number of times.
- Remove locking pliers.

STEP 14 - STANDARD TORSION SPRING INSTALLATION

Step 14-9: Opening the Door for the First Time

- Be sure horizontal tracks are parallel with each side of the door.
- Make sure lag screws are securely fastened.
- Slowly open the door manually about halfway and make sure rollers do not come out of the top brackets more than 1/2".
- Note: if adjustment is necessary, close the door and lock it in the closed position.
- Gently release the door to determine if the springs are properly balanced. The door should hang in place and not raise or lower.
- Now lift the door all the way open and then close it. It should be easily controlled when lifting and lowering.

Step 14-10: Adjusting Torsion Spring Tension (If Necessary)

⚠ WARNING

Reducing spring tension requires strong force. Only use winding bars and stand to the side. NEVER adjust center bearing plate or red-colored fasteners after springs are wound. Failure to do so may cause spring tension to release causing property damage or serious injury.

- Close the door all the way and lock it in the down position.
- Use locking pliers to clamp the torsion tube in place.
- Use winding bars to adjust tension 1/4 turn at a time. Increase tension with more turns or reduce tension by removing turns.
- Repeat for second spring if applicable. Each spring should be wound the same number of times.

STEP 15 - SOLID STEEL SHAFT TORSION SPRING INSTALLATION

This step is to be completed after Step 14-1.

Step 15-1: Install Wood Anchor Pad

- Measure from top of door to end bearing and draw a line at the same height for shaft location over the center of the door.
- Using at least (4) long lag screws for wooden frames (or (4) 3/8" × 4" sleeve anchors for concrete frames), attach (2) 2" × 6" wood anchor pads to the frame of the garage across the center of door. Fasteners should be located in each corner of anchor pad, but no closer than 1-1/2" from the edge. (Fig.15-A).

NOTE: Header and side jambs should extend 12" above the top of the opening for 12" radius and 15" above the top of the opening for 15" radius (Fig. 15-A). Wood anchor pad may be off center to width of the opening by up to 10" in either direction.

IMPORTANT: Wood anchor pad must be made of Grade 2 or better southern yellow pine (also known as southern pine or yellow pine), beech, birch, hickory or oak. It must be free of cracks or splits. Do not use spruce pine fir (SPF).

- Do not attach anchor pad to drywall or sheet rock.
- Do not use nails.

Step 15-2: Lock the Door in Down Position

- Using door lock or locking pliers, lock door in down position securely.

NOTE: Following steps require an assistant. Prior to locking the door be sure you, your assistant and tools needed are inside the garage.

⚠ CAUTION

Locking the door in the down position prevents the door from prematurely opening. Failure to do so could cause the door to open causing injury.

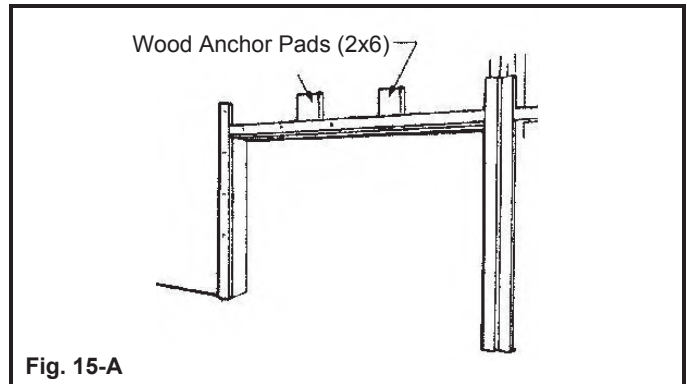

STEP 15 - SOLID STEEL SHAFT TORSION SPRING INSTALLATION

Step 15-3: Torsion Spring Assembly

⚠ WARNING

Failure to install torsion springs on the correct side will cause your door to function improperly and could result in property damage or serious injury.

- Slide the steel shaft coupler, a spring anchor bracket, torsion spring (left wound) with black winding cone, and black cable drum onto one section of the steel shaft (Fig. 15-B).
- Insert solid shaft key into coupler and tighten the two set screws (Fig. 15-C).
- Slide second spring anchor bracket, torsion spring (right wound) with red winding cone, and red cable drum onto the other side of the steel shaft (Fig. 15-D).

NOTE: Set screws on the drums should face the springs.

Step 15-4: Mount Spring Assembly to Wall

⚠ WARNING

The spring anchor bracket secures the springs to the wall. You must fasten securely with red-colored fasteners. Failure to do so could cause spring assembly to disengage causing property damage or serious injury.

- Never remove spring anchor bracket when springs are wound.
- With an assistant, slide either shaft end into corresponding end bearing on the end bearing plates.
- Center on the mark made previously for the spring anchor pads.
- Drill (2) 3/16" pilot holes into spring anchor pad, no closer than 1-1/2" from edge.
- Mount the center bearing plate to center anchor pad using (2) 5/16" × 1-5/8" red-headed lag screws.
- Repeat for the other side of the shaft.

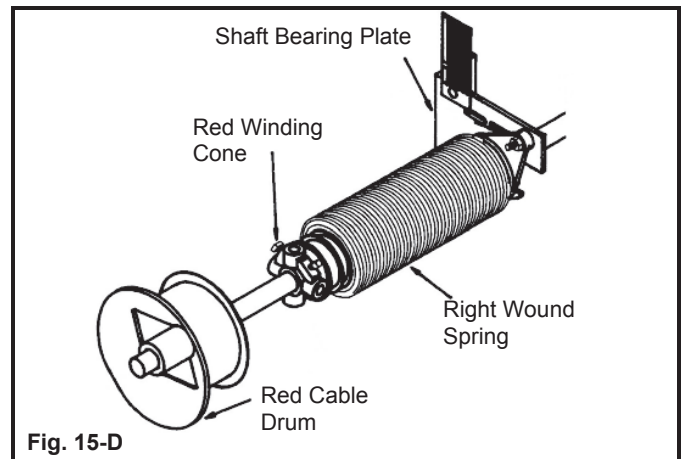
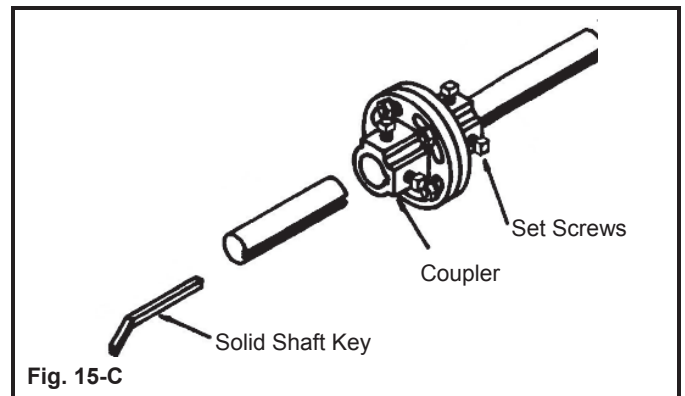
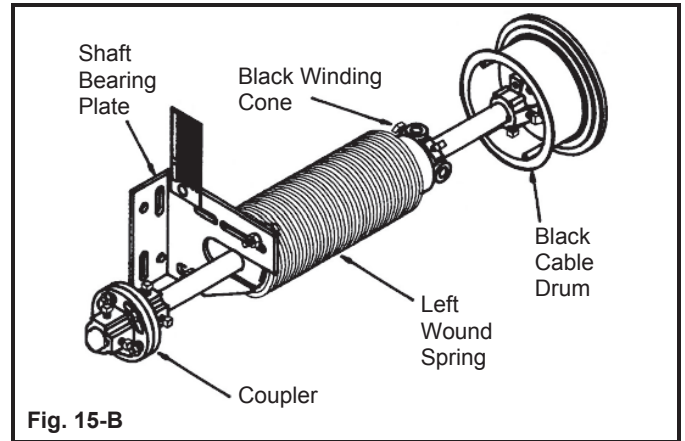

STEP 15 - SOLID STEEL SHAFT TORSION SPRING INSTALLATION

Step 15-5: Connect Spring Assembly

- Connect spring(s) to corresponding center bearing plate. Use (2) 3/8" × 1" hex bolts and nuts for single springs or (2) 3/8" × 1-5/8" hex bolts and nuts for double springs (Fig. 15-E).
- Slide each cable drum against end bearings and insert solid shaft keys. Using a 3/8" box wrench tighten set screws.

Step 15-6: Attach Lift Cables

- Bring up left side cable (inside garage looking out) between wall and roller shafts to cable drum.
- Attach cable by placing in notch on cable drum.
- Turn drum by hand and slide cable up tight against end bearing plate to remove cable slack. Be sure cable follows grooves in cable drum.
- While holding cable taught, tighten set screws on cable drum using 3/8" box wrench.

CAUTION

Set screws should only be turned from 3/4 to one full turn after they have made contact with tube.

- Clamp locking pliers on torsion spring tube to maintain tension on cable.
- Repeat cable attachment for the right side.

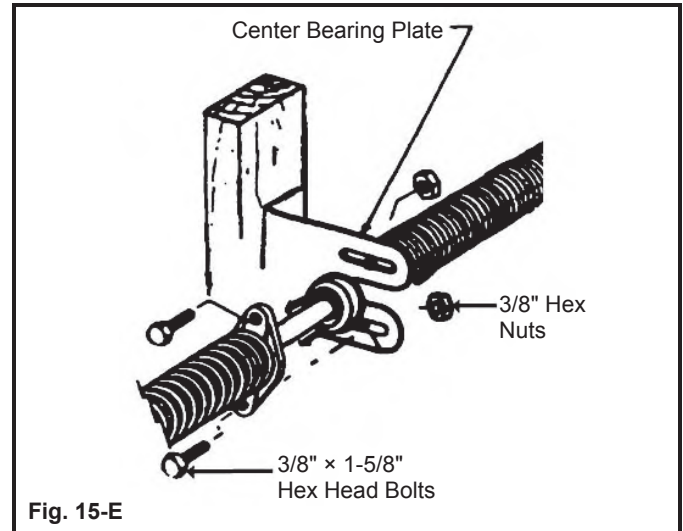

Fig. 15-E

Step 15-7: Connect Shaft

- Using the remaining set screws, bolt the shaft coupler together.
- Return to Step 14-6 to finish installation.

STEP 16 - LOW HEADROOM FRONT TORSION SPRING INSTALLATION

This step is to be completed after Step 14-4.

STEP 16-1: Install Wood Anchor Pad

- Slide the torsion spring(s), steel center bearing, and center bearing plate onto the spring tube.
- From left to right, inside the garage facing out, parts should be: left side spring (right wound) with stationary cones facing the center of the door, steel center bearing, center bearing plate, right side spring (left wound) with stationary cones facing the center of the door (Fig. 16-A).

Step 16-2: Mount Spring Assembly to Wall

WARNING

The spring anchor bracket secures the springs to the wall. You must fasten securely with red-colored fasteners. Failure to do so could cause spring assembly to disengage causing property damage or serious injury.

Never remove spring anchor bracket when springs are wound.

- With an assistant, lift the complete torsion spring tube assembly and slide ends of tube into bearings on the end bearing plates.
- Check to make sure the tube is level and aligns with the mark drawn previously for the spring anchor pad.
- Drill (2) 3/16" pilot holes into spring anchor pad, no closer than 1-1/2" from edge.
- Mount the center bearing plate to center anchor pad using (2) 5/16" × 1-5/8" red-headed lag screws.

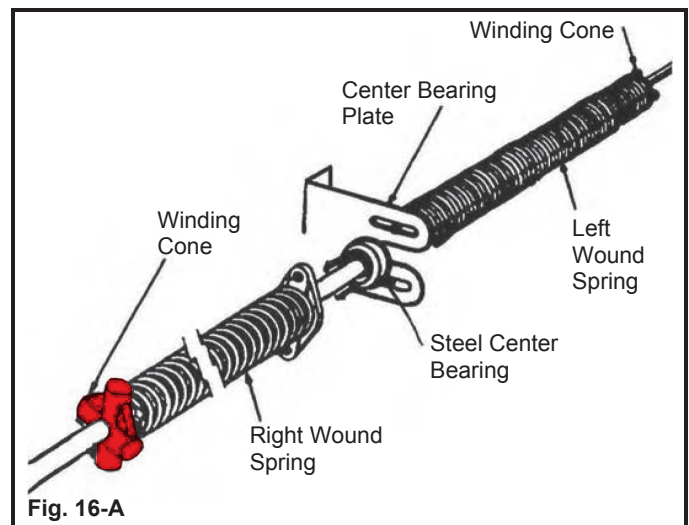

Fig. 16-A

Step 16-3: Install Cable Drums

- Slide cable drums onto both ends of the torsion tube on the outside of the bearing plates. From the inside looking out, the left drum will go on the left side and the right drum will go on the right side. Be sure the set screws are facing outward away from the springs.
- Return to Step 14-6 to complete installation.

STEP 17 - ATTACH AUTOMATIC GARAGE DOOR OPENER

IMPORTANT: To avoid damage to door, you **MUST** reinforce top section of door in order to provide a mounting point for opener to be attached. Refer to STEP 10 – Reinforcing the Top Section. Failure to reinforce door as illustrated will void door warranty.

⚠ WARNING

To avoid risk of strangulation or personal injury, if door has a pull rope, you must remove pull rope when you install an automatic garage door opener.

⚠ CAUTION

If you have installed a door lock, disable or remove at this time. Failure to do so may cause damage to the door and void the warranty.

Step 17-1: Remove Pull Rope and Lock

- If installed, remove pull rope and locks (or unlock).

Step 17-2: Install Opener Head and Rail

IMPORTANT: When installing an automatic garage door operator, follow manufacturer's installation and safety instructions carefully.

- To prevent top of door from bending, opener rail should be mounted no less than 2" and no greater than 5" from face of door in open position (Fig. 17-A).
- Follow operator manufacturer's instructions.

Step 17-3: Attach Opener Arm to Door

- Attach opener arm to vertical reinforcement (Fig. 17-B through 17-D).
- Attachment should be roughly same height as top roller of door.
- When door is in down position, door should be at angle of approximately 60 degrees from vertical operator bracket (Fig. 17-B).

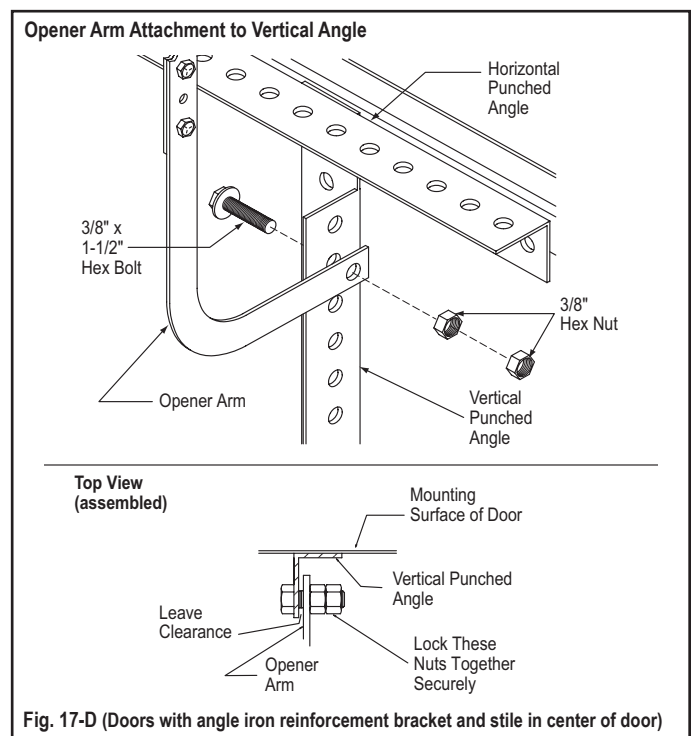
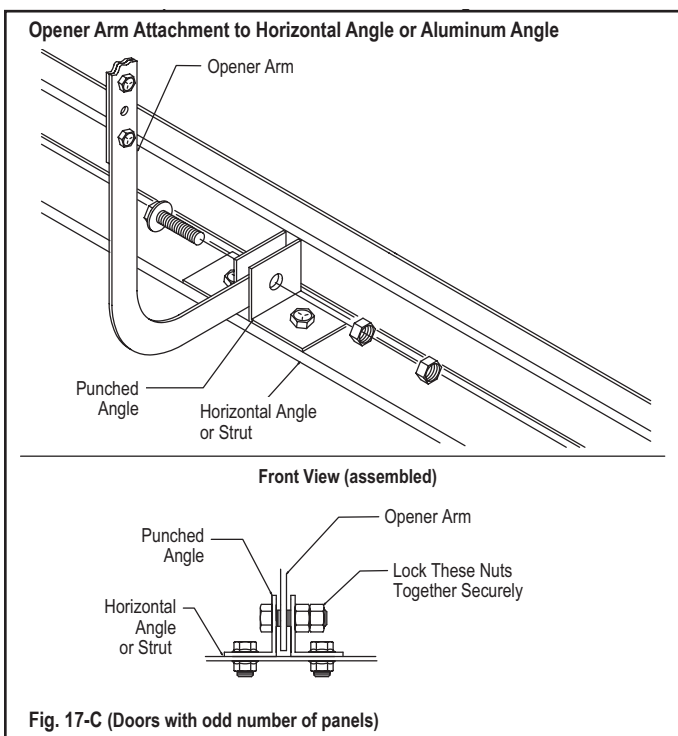
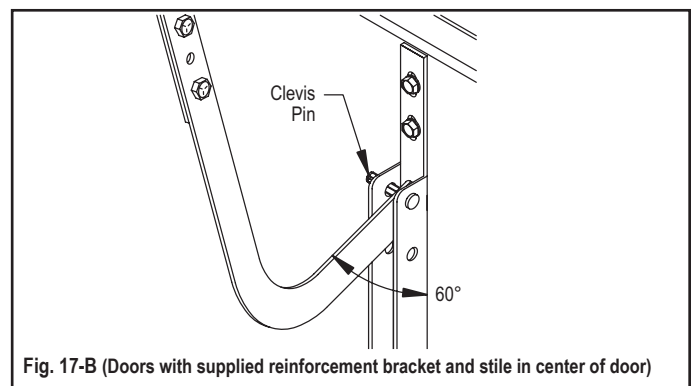
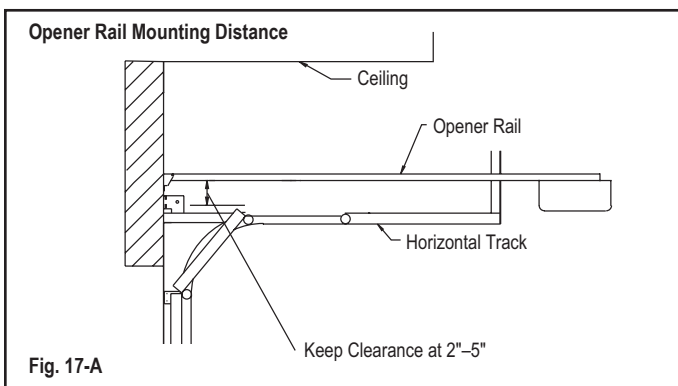

PERIODIC MAINTENANCE

FOR ALUMINUM GARAGE DOORS

APPLIES TO THE FOLLOWING MODELS: **AX,AXU**

Your door will need regular inspection, lubrication and cleaning. The following checklists will help keep your door and its parts in good working order and help protect it from the elements.

⚠ WARNING

A sectional garage door is a large, heavy object that moves with the help of springs under high tension. Springs, bottom brackets, cables and associated hardware are under high tension and can cause death, serious injuries or damage to the door if not properly handled. For your safety and the safety of others, follow these instructions:

- DO NOT loosen or remove bottom bracket with the spring tension engaged.
- DO NOT operate door with a broken spring.
- DO NOT manually operate door if handles are not installed or functioning properly.
- DO NOT operate door if it is too difficult to move, opens too quickly or the rollers come out of the track.
- DO NOT operate the door if glass or interior window retainer appears to be loose, cracked or warped.
- DO NOT remove screws on inside retainer.
- For assistance with these maintenance steps, repair or replacement of any parts, please contact your professional installing Clopay Dealer: <https://www.clopaydoor.com/where-to-buy>

VISUAL INSPECTION CHECKLIST

Monthly inspection of the door and all of its components is recommended. If something seems out of balance or adjustment, or you note any of the following, please contact your Clopay Dealer or Clopay Consumer Services at 800-225-6729.

Visually inspect the door when in the down position for:

- Loose or bent hinges.
- Broken wheels, bent shafts or worn out bearings on rollers.
- Loose or missing bolts, screws or other fasteners on the door or track.
- Creases or bends in the track.
- Cracking or fatigue of the door panels.
- Damaged or broken springs or spring components. If the spring looks broken it will need replaced.
- Standard extension springs that run alongside the door should include a safety containment cable. For a visual of the safety containment cable, scan the QR code on Page 30.
- Worn or frayed cables.
- Loose, cracked or warped glass panels or inside glass retainers. Inside the door, the plastic retainer holding the glass and its fasteners should appear secure.

- Tears or gaps in the bottom weather seal or perimeter seal.
- Tears or gaps in the section joint seals.
- Any covered, ripped, damaged or missing warning labels.
- Any missing, broken, loose or malfunctioning door handles. There should be two lifting points on the outside and two on the inside of the garage door.

INSPECTING WINDOW AND/OR ALUMINUM PANELS

We recommend that you inspect your window and/or aluminum panels every twelve months, at a minimum.

⚠ WARNING

If glass or retainers appear to be or feel loose, warped, cracked, broken, shrunk or misshaped, immediately discontinue use of the door. Failure to do so may result in glass falling out of the panel, causing property damage, serious injury or death. Contact your Clopay dealer or Clopay Consumer Services at 800-225-6729 for assistance.

- **Inspect the window and aluminum panels.**
 1. With the door closed and locked, disconnect the garage door opener.
 2. From inside and outside the garage, visually inspect all panels to ensure they are not loose, cracked or warped.
 3. From inside the garage, visually inspect the edge of each panel retainer for any shrinkage, loosening, cracking, warping or misshaping. Proper retainers should not show any gaps in the corner(s) of the window areas and should appear flat, straight and flush with the window/aluminum panel.
 4. Physically inspect the retainers by pressing the center of each retainer. You should feel little to no movement and not be able to compress the retainer more than 1/8".

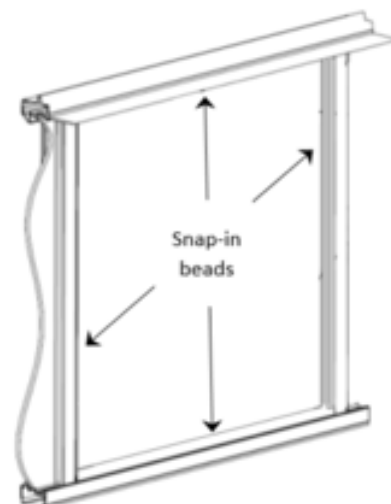

PERIODIC MAINTENANCE

DOOR OPERATION CHECKLIST

We recommend that at least twice per year after you have visually inspected the door and all of its components, that you.



□ Check the balance of the door.

1. With the door in the down position, detach the opener (if applicable) by pulling down on the red manual release handle.
2. Next lift the door manually up to the halfway point and gently release the door. A balanced door should hang in place and not raise or lower. If the door does not stay in place contact your Clopay Dealer for adjustment.

□ Check the door operation.

1. Once you have determined your door is in balance, lift the door up and down to ensure smooth operation. The door should be easily controlled when lifting and lowering.

NOTE: Be sure to reattach the opener once you confirm the door is operating properly.

□ Safety feature for doors with automatic operators.

1. Make sure that the operator has a working safety feature. Photo eyes should be mounted to the left and right sides of the bottom of the door opening.
2. Make sure any door locks are disabled or removed if the door has an automatic operator.
3. Retest following opener manufacturer's instructions.

LUBRICATE THE DOOR

At least twice per year lubricate all moving parts of the door with Clopay Garage Door Pro Lube or a synthetic lubricant:

- Lift cables at bottom bracket button.
- Lock hardware where surfaces turn or slide.
- Full length of torsion spring to reduce friction between coils.
- Rollers at the bearing (but not the tire).
- Hinges

CLEANING AND PRESERVING THE DOOR

Doors must be cleaned at least twice a year or four times a year for harsh environments (such as coastal regions, high road salts, etc.). Failure to do so may result in loss of warranty coverage. For further questions about the requirements, contact Clopay Consumer Services.

- Helps prevent damage caused by foreign matter or salt adhering to the door.
- Assists to restore the look of factory-applied finish by removing dirt and chalking.

CLEANING THE DOOR

- Working from top to bottom of the door sections, use a well soaked cloth, sponge or soft bristle brush.
- A household liquid dishwashing detergent may be used to clean more soiled areas.

- A fine scouring pad may be used for heavy surface soils. Be sure to scrub with the direction of the metal grain and do not apply too much pressure.
- DO NOT use scouring powders or solvents, alkaline or acid cleaners.
- Avoid cleaning in the hot sun.
- Rinse door with clean water to complete cleaning and allow to dry.

NOTE: Be sure to clean behind stop molding on the sides and top of the door.

REPAIRING OR PAINTING THE DOOR

Surface damage can be easily repaired providing the damage is slight; such as a small scratch or rub mark.

REPAIRING OR PAINTING — ANODIZED ALUMINUM FINISH DOOR

- Rub marks can be removed with a mild abrasive pad such as the Scotch-Brite™ pad prior to touch-up painting.
- NOTE: DO NOT sand the anodized material when touching up.
- Clean the area to be touched up with denatured alcohol to remove moisture.
- Apply touch-up paint (not provided) very sparingly as this is intended for small blemishes less than a few square inches.

NOTE: For more severe damage or repainting we recommend contacting a professional who specializes in the refinishing of architectural metals.

REPAIRING OR PAINTING — PAINTED ALUMINUM FINISH DOOR

- Minor damage to the painted surface should be sanded prior to application of the touch-up paint.
- Clean the area to be touched up with denatured alcohol to remove moisture.
- Apply the provided touch-up paint very sparingly as this is intended for small blemishes less than a few square inches.

NOTE: For more severe damage or repainting we recommend contacting a professional who specializes in the refinishing of architectural metals.

WINDOW CARE

- Clean with a mild solution of a dishwashing detergent and a soft cloth. DO NOT use any ammoniated, abrasive or solvent-based cleaners of any kind.

FOR ACRYLIC OR POLYCARBONATE WINDOWS:

- These windows CAN ONLY be washed using a clean, soft sponge or cloth with a mild dish soap and lukewarm water. Dry with soft cloth or chamois to prevent spotting.
- DO NOT use any ammoniated, abrasive or solvent-based cleaners of any kind.
- DO NOT brush, scrub or scrape these windows.
- After cleaning, rinse thoroughly.

CAUTION

Use care when handling decorative windows to avoid scraping or scratching the surface.

GLASS REPLACEMENT

WARNING

DO NOT try to replace the glass yourself.

- If glass should need replacement, contact an authorized professional dealer.

AUTOMATIC GARAGE DOOR OPENERS

If you are installing an automatic garage door opener, installation of a reinforced mounting point is required. To avoid damage to your door, you must reinforce the top section of the door in order to provide a mounting point for the garage door opener to be attached. DO NOT use the bracket that came with your opener or attach it directly to the door. Failure to reinforce the door as required may result in loss of warranty coverage.

LIMITED WARRANTY

ALUMINUM GARAGE DOORS

Subject to the terms of this Limited Warranty ("Warranty") and any warranty policies and procedures in effect at the time a notice of a claim is received, Clopay Corporation ("Clopay", "we", or "our") will repair or replace (at our sole discretion) any garage door sections/section components, hardware, or springs/spring components (collectively, "Replacement Parts") that we determine to be defective in material or workmanship so long as timely written notice is provided within the applicable limited warranty periods provided below. This Warranty shall apply and benefit only the original purchase of a Clopay garage door product and is non-transferable, and does not apply to decorative hardware or to any commercial, industrial or other non-residential application/installation.

The warranty period begins from the date of delivery or installation, up to a maximum of one (1) year from the date of purchase. Proof of purchase is required. Once we have verified any defect(s) with your product through persons authorized by Clopay, we will provide – at no cost to you – Replacement Parts to the extent necessary to repair or replace any such defective sections, hardware, or springs/spring components. We reserve the right to inspect and/or verify any claimed defect, as well as the right to replace product(s) with a similar or like product, all within the sole discretion of Clopay. All labor costs associated with any warranty claim (including removal, reinstallation, installation, and/or finishing) will be your responsibility.

The applicable Warranty periods are as follows:

MODEL NUMBER	PAINT FINISH	SECTIONS/ DELAMINATION	WINDOWS	HARDWARE
AV, AVI, AX, AXU	Single Family* – 5 Years Other** – 1 Year Color Blast® – 5 Years	3 Years	5 Years (insulated glass)	3 Years

Terms and limitations of the limited warranty are further detailed below:

* Applies to residential single family installations.

** "Other" refers to all other residential installations (including installations on facilities owned in common by condominium associations or similar organizations).

ADDITIONAL INFORMATION REGARDING YOUR WARRANTY

Clopay warrants the sections of the Models listed above against the paint finish cracking, checking or peeling (i.e. losing adhesion). We warrant our rust prevention system against rust through perforation(s) caused by corrosion originating at the steel layer. Failure to properly clean and maintain your door (particularly in, but not limited to, high-salt or acidic environments) or damage to the door such as scratching, may result in surface rust, a coating that forms on the surface when exposed to moisture, which – if left untreated – may result in loss of warranty coverage. Surface rust is not covered under this warranty. For more information about our rust prevention system and how to care for your door visit: info.garagedoors.com/maintenance.

Insulated windows are warranted for five (5) years for material obstruction of vision resulting from film formation or dust or moisture collection between the interior surface of the insulating glass. No warranty is available for single pane glass. No warranty is available for decorative hardware.

EXCLUSIONS TO COVERAGE

This warranty shall not extend to damages or defects caused by any of the following:

Paint or Stain Not Applied per Manufacturer Specifications after Delivery of Door	Failure to Follow All Installation Instructions	Failure to Follow Maintenance Instructions	Faulty or Defective Installation(s)
Fire	Radiation (UV or Other)	Foreign Substances	Accident or Casualty
Harmful Fumes	Vandalism	Act(s) of God	Physical Damage
Salt Spray or Exposure	Normal Wear and Tear	Chemical Action	Abrasive Materials
Operation Beyond Rated Capacity	Improper Use or Abuse	Improper Installation or Handling	Exposure to Coastal Weather Conditions
Alteration, Modification or Use of Non-OEM/ Clopay-Approved Parts or Products	Other Painted Parts Not Part of a Door Section (such as stop mold)	Normal Fading or Discoloration from Usage, Age or UV Exposure	Thermal bow as described in DASMA Technical Data Sheet 185 www.dasma.com

If you make any repair or alteration without first providing notice to and receiving authorization from us, or use any parts, accessories, or attachments other than authorized by Clopay for use in its products, you will be solely responsible for any such repairs or parts and you may void this Warranty. Routine maintenance and related items, as well as minor adjustments or damage caused by your installer either during delivery or installation, are excluded from this Warranty. For purposes of this Warranty, minor scratches will not be considered a defect.

If you would like to submit a Warranty claim, notify Clopay Customer Service promptly after discovery of the defect by sending an email to warranty@clopay.com or calling 800-225-6729. Please be prepared to send us a proof of purchase and complete description with photographs of any issues. YOU MUST REPORT ANY MANUFACTURING DEFECTS THAT ARE IMMEDIATELY OBVIOUS OR VISIBLE AT THE TIME OF INSTALLATION (SUCH AS INCORRECT OR INCONSISTENT PAINT COLOR, MANUFACTURING DEFECTS (E.G. SURFACE CONTAMINANT(S) OR SMUDGES), VISIBLE PHYSICAL DAMAGE, OR MAJOR SCRATCHES) WITHIN FORTY FIVE (45) DAYS FROM DELIVERY OR YOUR CLAIM MAY BE BARRED. Additional copies of our installation and maintenance instructions may be obtained by calling 800-225-6729.

UNDER NO CIRCUMSTANCES SHALL WE BE LIABLE FOR ANY CONSEQUENTIAL OR SPECIAL DAMAGES WHICH ANY PERSON OR ENTITY MAY INCUR OR CLAIM TO INCUR AS A RESULT OF ANY DEFECT IN THE PRODUCT OR IN ANY CORRECTION OR ALTERATION THEREOF MADE OR FURNISHED BY US OR OTHERS. OUR MAXIMUM LIABILITY UNDER THIS WARRANTY SHALL BE THE PURCHASE PRICE PAID TO US WITH RESPECT TO THE GARAGE DOOR TO WHICH SUCH WARRANTY IS CLAIMED. THE LIMITATION OF LIABILITY PROVISIONS HEREIN SHALL APPLY TO ANY AND ALL CLAIMS OR SUITS BROUGHT AGAINST US, INCLUDING ANY CLAIM BASED UPON NEGLIGENCE, BREACH OF CONTRACT, BREACH OF WARRANTY, STRICT LIABILITY OR ANY OTHER THEORIES UPON WHICH LIABILITY MAY BE ASSERTED AGAINST US.

This warranty constitutes our entire and exclusive warranty as to the Replacement Parts and is the sole and exclusive remedy for product defects in material and workmanship. We do not assume (and have not authorized any other person to assume on its behalf) any other warranty or liability in connection with any product covered by this warranty. WE MAKE NO OTHER WARRANTIES, REPRESENTATIONS OR COVENANTS, EXPRESS OR IMPLIED, WITH RESPECT TO THIS PRODUCT, INCLUDING BUT NOT LIMITED TO WARRANTIES, REPRESENTATIONS OR COVENANTS AS TO WORKMANSHIP, DESIGN, CAPACITY, QUALITY, CONDITION, MERCHANTABILITY OR FITNESS FOR ANY PURPOSE OF THE PRODUCT, EXCEPT FOR ANY "IMPLIED WARRANTY" AS THAT TERM IS DEFINED IN THE MAGNUSON-MOSS WARRANTY-FEDERAL TRADE COMMISSION IMPROVEMENT ACT, SUCH IMPLIED WARRANTIES TO BE LIMITED IN DURATION TO A PERIOD OF ONE YEAR FROM THE DATE OF PURCHASE.

This warranty gives you specific legal rights, and you may also have other rights that vary from state to state.



© 2019 Clopay Corporation. All rights reserved.

AV1-R06-0919